

# Model VSL-337ND-S

---

Pulsed UV, Air-Cooled, Nitrogen Laser System

*User's Manual*



1335 Terra Bella Avenue  
Mountain View, CA 94043

Part Number 0000-318A, Rev. A  
May 2004



## Preface

---

This manual contains information required to safely install, operate, maintain, and service your *VSL-337ND-S* pulsed, ultraviolet nitrogen laser system. The system comprises a single, self-contained unit that includes the laser resonator, power supply and control circuitry.

The “Introduction” contains a brief description of the laser system and available accessories.

Following that section is an important chapter on safety. The *VSL-337ND-S* is a Class IIIb laser and, as such, emits laser radiation that can permanently damage eyes and skin. This section contains information about these hazards and offers suggestions on how to safeguard against them. To minimize the risk of injury or expensive repairs, be sure to read this chapter—then carefully follow these instructions.

“Laser Description” contains a short section on laser theory relevant to nitrogen lasers. It is followed by a more detailed description of the laser system and concludes with system specifications.

The next few chapters describe the *VSL-337ND-S* controls, then guide you through its installation and operation. The last part of the manual covers service and includes a replacement parts list and a list of world-wide Spectra-Physics service centers to call if help is ever needed.

“Service and Repair” is intended to help you guide your Spectra-Physics field service engineer to the source of any problems. *Do not attempt repairs yourself while the unit is still under warranty*; instead, report all problems to Spectra-Physics for warranty repair. This section includes instructions for the replacement of the laser plasma cartridge, which is engineered for easy servicing in the field.

This product has been tested and found to conform to Low Voltage Directive 72/23/EEC governing product safety using standards EN 60950:1992 (with Amendment 14424 Safety of information technology equipment, including electrical business equipment, including Amendment 1: 1993, Amendment 2:1994, Amendment 3:1996, Amendment 4:1997 and Amendment 11: 1997), and IEC 60825-1:1993 Safety of Laser Products—Part 1: Equipment classification, requirements and user's guide (including Amendment A1:1997 and Amendment A2:2001). This product also conforms to Directive 89/336/EEC governing electromagnetic compatibility using standard EN 61326-1:1997 Electrical equipment for measurement, control, and laboratory use—EMC requirements (including Amendment 1:1998 and Amendment 2: 2000) as listed in the official Journal of the European Communities. Refer to the “CE Declaration of Conformity” document in Chapter 2 for a complete list of directives to which this system complies.

This product conforms to the requirements of 21 CFR 1040.10 and 1040.11 CDRH and uses a power supply that is a UL recognized (ULR) component. It has also been designed and tested to comply with the limits for a Class B digital device pursuant to Part 15 of the FCC Rules.

The laser, when in the shipping container, has been tested for Shock and Vibration and been found to comply with International Safe Transit Association Standard ISTA 2-A.

Should you experience any problems with any equipment purchased from Spectra-Physics or are in need of technical information or support, please contact Spectra-Physics as described in “Customer Service.” This chapter contains a list of world-wide Spectra-Physics service centers you can call if you need help.

Every effort has been made to ensure that the information in this manual is accurate. All information in this document is subject to change without notice. Spectra-Physics makes no representation or warranty, either express or implied, with respect to this document. In no event will Spectra-Physics be liable for any direct, indirect, special, incidental or consequential damages resulting from any defects in this documentation.

Finally, if you encounter any difficulty with the content or style of this manual, or encounter problems with the laser itself, please let us know. The last page of this manual is a form to aid in bringing such problems to our attention.

Thank you for your purchase of Spectra-Physics instruments.

# Environmental Specifications

---

## CE Electrical Equipment Requirements

For information regarding the equipment needed to provide the electrical service listed in “Specifications” in Chapter 3, please refer to specification EN-309, “Plug, Outlet and Socket Couplers for Industrial Uses,” listed in the official *Journal of the European Communities*.

## Environmental Specifications

The environmental conditions under which the laser system will function are listed below:

### Indoor use

Altitude:	up to 3000 m
Temperatures:	4°C to 40°C
Maximum relative humidity:	85% non-condensing for temperatures up to 35°C.
Mains supply voltage:	do not exceed $\pm 10\%$ of the nominal voltage
Insulation category:	II
Pollution degree:	2

## FCC Regulations

This equipment has been tested and found to comply with the limits for a Class B digital device pursuant to Part 15 of the FCC Rules. These limits are designed to provide reasonable protection against harmful interference when the equipment is operated in a commercial environment. This equipment generates, uses and can radiate radio frequency energy and, if not installed and used in accordance with the instruction manual, may cause harmful interference to radio communications. Operation of this equipment in a residential area is likely to cause harmful interference in which case the user will be required to correct the interference at his own expense.

Modifications to the laser system not expressly approved by Spectra-Physics could void your right to operate the equipment.

## CDRH Regulations

This product conforms to the requirements of 21 CFR 1040.10 CDRH.



# Table of Contents

---

- Preface . . . . .iii**
- Environmental Specifications. . . . . v**
  - CE Electrical Equipment Requirements . . . . .v
  - Environmental Specifications . . . . .v
  - FCC Regulations . . . . .v
  - CDRH Regulations . . . . .v
- Warning Conventions . . . . .xi**
- Standard Units . . . . .xiii**
- Abbreviations . . . . . xv**
- Unpacking and Inspection . . . . . xvii**
- Chapter 1: Introduction . . . . . 1-1**
  - Key Features . . . . . 1-2
  - CE, CDRH, and FCC Compliance and Certification . . . . . 1-2
- Chapter 2: Laser Safety. . . . . 2-1**
  - Hazards . . . . . 2-1
  - Precautions For The Safe Operation
    - Of Class IIIb Medium Power Lasers . . . . . 2-2
  - Maximum Emission Levels and Protective Eye Wear . . . . . 2-3
  - Safety Devices . . . . . 2-3
    - Interlock Keyswitch . . . . . 2-3
    - Emission and Power Indicator . . . . . 2-4
    - Shutter . . . . . 2-4
    - Remote Interlock . . . . . 2-4
    - Interlocks Defeat Indicator . . . . . 2-5
    - External Trigger Connector . . . . . 2-5
    - Burst Input Connector . . . . . 2-5
    - Cover Safety Interlock . . . . . 2-5
  - Maintenance Necessary to Keep this Laser Product in Compliance with Center for Devices and Radiological Health (CDRH) Regulations . . . . . 2-6
  - CE/CDRH Radiation Control Drawing. . . . . 2-7
  - CE/CDRH Warning Labels . . . . . 2-8
    - Label Translations . . . . . 2-9
  - CE Declaration of Conformity . . . . . 2-10
  - Sources for Additional Information . . . . . 2-11
    - Laser Safety Standards . . . . . 2-11
    - Equipment and Training . . . . . 2-12

**Chapter 3: Laser Description . . . . . 3-1**

- A Brief Review of Laser Theory . . . . . 3-1
  - Emission and Absorption of Light . . . . . 3-1
  - Population Inversion . . . . . 3-2
  - Nitrogen as a Laser Medium . . . . . 3-3
  - The Optical Cavity . . . . . 3-4
- The VSL-337ND-S Nitrogen Laser . . . . . 3-5
  - Output Pulse . . . . . 3-6
  - Beam Cross Section . . . . . 3-6
  - High Voltage Power Supply . . . . . 3-7
  - Trigger Control . . . . . 3-8
  - Output Synchronization . . . . . 3-8
- Specifications . . . . . 3-9
  - Replaceable Plasma Cartridge . . . . . 3-10
  - Outline Drawing . . . . . 3-11

**Chapter 4: Controls, Indicators and Connections . . . . . 4-1**

- Front Panel . . . . . 4-1
  - Controls . . . . . 4-1
- Rear Panel . . . . . 4-1
  - Controls . . . . . 4-2
  - Indicators . . . . . 4-2
  - Connections . . . . . 4-2

**Chapter 5: Operation. . . . . 5-1**

- Precautions . . . . . 5-1
- Basic Operation . . . . . 5-1
- Burst Control . . . . . 5-2
  - Pulse Gating . . . . . 5-2
  - Burst Output . . . . . 5-3
  - Suppression of Spontaneous Pulses . . . . . 5-4
  - Noise Suppression . . . . . 5-4
  - Electronic Control of Laser Energy . . . . . 5-6
- Using the OPTOSYNC Output . . . . . 5-7

**Chapter 6: Maintenance and Service. . . . . 6-1**

- Replacing the Plasma Cartridge . . . . . 6-1
  - Required Tools . . . . . 6-1
  - Procedure . . . . . 6-1
- Troubleshooting . . . . . 6-6
- Accessories . . . . . 6-6
- Replacement Parts . . . . . 6-6
- Service . . . . . 6-7
  - Warranty . . . . . 6-7
  - Returning the Instrument for Repair . . . . . 6-8
- Service Centers . . . . . 6-9

**Notes**

**Report Form for Problems and Solutions**



## List of Figures

Figure 1-1: The VSL-337ND-S Nitrogen Laser	1-1
Figure 2-1: These CE and CDRH standard safety warning labels would be appropriate for use as entry warning signs (EN 60825-1, ANSI 4.3.10.1).	2-2
Figure 2-2: Folded Metal Beam Target	2-2
Figure 2-3: The VSL-337ND-S laser, showing the location of the safety devices on the front (upper figure) and rear (lower figure) panels.	2-4
Figure 2-4: Remote Interlock Connector	2-4
Figure 2-5: CE/CDRH Radiation Control Drawing	2-7
Figure 2-6: CE/CDRH Warning Labels	2-8
Figure 3-1: Electrons occupy distinct orbitals in an atom or molecule. Two different distributions are shown.	3-1
Figure 3-2: A typical four-level transition scheme	3-3
Figure 3-3: The long lifetimes of the lower molecular energy levels are responsible for the pulsed nature of the nitrogen laser output.	3-4
Figure 3-4: VSL-337ND-S Internal Components	3-5
Figure 3-5: Typical output pulse, VSL-337ND-S	3-6
Figure 3-6: Typical profile of the VSL-337ND-S laser beam	3-6
Figure 3-7: A representation of the VSL-337ND-S laser cavity	3-7
Figure 3-8: Outline Drawing for the VLS-337ND-S Laser	3-11
Figure 4-1: VSL-337ND-S Front Panel	4-1
Figure 4-2: VSL-337ND-S Rear Control Panel	4-1
Figure 4-3: Remote Interlock Connector	4-3
Figure 4-4: The timing between the trigger signal, the laser pulse, and OPTOSYNC output.	4-4
Figure 4-5: Oscilloscope trace of the trigger pulse, the laser pulse, and OPTOSYNC output.	4-5
Figure 5-1: Gating of 30-Hz Pulses Using the Burst Signal	5-2
Figure 5-2: Pulse Energy vs. Repetition Rate	5-3
Figure 5-3: HVPS Recharge Noise	5-5
Figure 5-4: The Noise Spectrum With (above) and Without (below) the HVPS Recharging Delay.	5-5
Figure 5-5: Pulse Attenuation vs. BURST Low Duration	5-6
Figure 5-6: Laser pulses captured using the SYNC input (top) versus the OPTOSYNC triggering input (bottom).	5-7
Figure 5-7: Example of Delay Compensation Using Coaxial Cable	5-8
Figure 5-8: OPTOSYNC Delay Compensation Using Coaxial Cable	5-8
Figure 6-1: Detach the OptoSync detector.	6-1
Figure 6-2: Detach the Trigger Connector	6-2
Figure 6-3: Detach the HVPS Connector	6-2
Figure 6-4: Unfasten the Plasma Cartridge Retaining Screws (4)	6-3
Figure 6-5: Ground Connections	6-3
Figure 6-6: Remove the Plasma Cartridge	6-4
Figure 6-7: Pulse Counter Connector	6-4
Figure 6-8: Spacer Orientation	6-5

## List of Tables

Table 2-1: Label Translations	2-9
Table 3-1: VSL-337ND-S Nitrogen Laser Output Characteristics	3-9
Table 3-2: Trigger Specifications and Characteristics	3-9
Table 3-3: Mechanical and Electrical Specifications	3-10
Table 3-4: Fuse Rating	3-10
Table 5-1: Burst Mode Duty Cycles	5-3
Table 6-2: Accessories	6-6
Table 6-1: Replacement Parts	6-6



# Warning Conventions

---

The following warnings are used throughout this manual to draw your attention to situations or procedures that require extra attention. They warn of hazards to your health, damage to equipment, sensitive procedures, and exceptional circumstances. All messages are set apart by a thin line above and below the text as shown here.

---



Laser radiation is present.

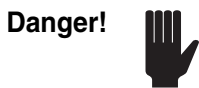

Condition or action may present a hazard to personal safety.



Condition or action may present an electrical hazard to personal safety.

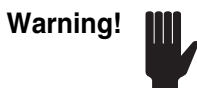

Condition or action may cause damage to equipment.

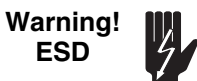

Action may cause electrostatic discharge and cause damage to equipment.



Condition or action may cause poor performance or error.

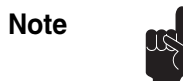

Text describes exceptional circumstances or makes a special reference.



Do not touch.



Appropriate laser safety eyewear should be worn during this operation.



Refer to the manual before operating or using this device.

---



## Standard Units

---

The following units, abbreviations, and prefixes are used in this Spectra-Physics manual:

Quantity	Unit	Abbreviation
mass	kilogram	kg
length	meter	m
time	second	s
frequency	hertz	Hz
force	newton	N
energy	joule	J
power	watt	W
electric current	ampere	A
electric charge	coulomb	C
electric potential	volt	V
resistance	ohm	$\Omega$
inductance	henry	H
magnetic flux	weber	Wb
magnetic flux density	tesla	T
luminous intensity	candela	cd
temperature	celcius	C
pressure	pascal	Pa
capacitance	farad	F
angle	radian	rad

Prefixes								
tera	$(10^{12})$	T	deci	$(10^{-1})$	d	nano	$(10^{-9})$	n
giga	$(10^9)$	G	centi	$(10^{-2})$	c	pico	$(10^{-12})$	p
mega	$(10^6)$	M	mill	$(10^{-3})$	m	femto	$(10^{-15})$	f
kilo	$(10^3)$	k	micro	$(10^{-6})$	$\mu$	atto	$(10^{-18})$	a



# Abbreviations

---

The following is a list of abbreviations used in this manual:

ac	alternating current
ACGIH	American Conference of Governmental and Industrial Hygienists
ANSI	American National Standards Institute
AOM	acousto-optic modulator
AR	antireflection
CDRH	Center for Devices and Radiological Health
CE	Conformite Europeenne
CW	continuous wave
dc	direct current
E/O	electro-optic
IEC	International Electrotechnical Commission
FHG	fourth harmonic generation
FWHM	full-width at half-maximum
HR	high reflector
IR	infrared
LBO	lithium triborate
Nd:YAG	neodymium-doped yttrium aluminum garnet
Nd:YLF	neodymium-doped yttrium lithium fluoride
Nd:YVO <sub>4</sub>	neodymium-doped Vanadate
OC	output coupler
RF	radio frequency
SCFH	standard cubic feet per hour
SHG	second harmonic generation
TEM	transverse electromagnetic mode
THG	third harmonic generation
UV	ultraviolet
$\lambda$	wavelength





## Unpacking and Inspection

---

Your *VSL-337ND-S* nitrogen laser was packed with great care, and its container was inspected prior to shipment—it left Spectra-Physics in good condition. The laser in the shipping container has been tested for Shock and Vibration and found compliant to International Safe Transit Association Standard ISTA 2-A.

Upon receiving your laser, immediately inspect the outside of the shipping container. If there is any major damage (holes in the containers, crushing, etc.), insist that a representative of the carrier be present when you unpack the contents and, before unpacking, take a photograph of the container for use if a claim must be filed.

Carefully inspect your laser system as you unpack it. If any damage is evident, such as dents or scratches on the covers or broken connectors, etc., immediately notify the carrier and your Spectra-Physics sales representative.

**Keep the shipping container.** If you file a damage claim, you may need it to demonstrate that the damage occurred as a result of shipping. If you need to return the system for service at a later date, the specially designed container assures adequate protection.

If the instrument has to be returned to Spectra-Physics for repair, *it must be sent in the shipping container with the original packing materials.*

When unpacking and carrying the laser, lift it by the bottom base plate, not the cover.

The *VSL-337ND-S* nitrogen laser is shipped in a single box. Any accessories ordered with the laser system (e.g., a dye laser attachment) are shipped in their own separate containers.





**Figure 1-1: The VSL-337ND-S Nitrogen Laser**

The *VSL-337ND-S* is a highly reliable, self-contained nitrogen laser that emits pulsed ultraviolet light at a wavelength of 337 nm with output pulses of 4 nanoseconds or less in duration. The pulse repetition rate can be varied from less than one pulse per second up to 60 Hz. The pulse energy is typically 300  $\mu\text{J}$ , with a peak pulse power of about 75 kW. Average output power is approximately 7 mW at a pulse repetition rate of 20 Hz.

The *VSL-337ND-S* emits a near-diffraction limited collimated beam with excellent homogeneity for this type of device. The beam can be focused to a spot less than 3  $\mu\text{m}$  in diameter, resulting in very high peak power density and an energy density of 4.5  $\text{kJ}/\text{cm}^2$ .

The *VSL-337ND-S* nitrogen laser features flexible triggering and control features for pulse gating or command charging applications, which simplifies the synchronization of the laser output to the timing of complex experiments. Both internal and external triggering is available, as well as a burst mode that allows higher repetition rates and broader control of pulse timing. A unique OptoSync output trigger provides a high-synchronization, low-delay and low-jitter signal.

All the sensitive components of the nitrogen laser—the energy storage capacitor, the spark gap switching element, the plasma tube, the electrodes, the pre-ionizers and the pre-aligned resonator mirrors—are contained in the integrated laser plasma cartridge module.

The plasma cartridge is polymer encapsulated and engineered for simple field replacement. The factory-aligned resonator mirrors are an integral part of the plasma cartridge, which eliminates the need to align the laser.

The plasma cartridge is warranted to maintain at least 70% of its energy for twenty million pulses or two years, whichever occurs first. The laser is factory-sealed, air-cooled, and requires no warm-up period. The auto-switching power supply automatically matches your line voltage.

Spectra-Physics offers a fiber-optic adapter, a variety of optical fibers, modular holders for filters, attenuators, energy meters, and other optical components for the most common nitrogen laser applications. This versatile laser may also be mated with either of two available dye lasers to obtain tunable output, from the infrared to the ultraviolet.

**Note**



---

A list of available accessories, including Spectra-Physics part numbers, is provided in Chapter 6.

---

## Key Features

The *VSL-337ND-S* includes the following features:

- flexible output control
- modular design for long life and high reliability
- uniform beam profile
- single, compact metal unit
- auto-switching power supply<sup>1</sup>
- CE certification

## CE, CDRH, and FCC Compliance and Certification

The *VSL-337ND-S* design incorporates RFI/EMI shielding, and the system complies with CE requirements for low radiated emissions and low voltage. The directives to which this system has been certified are listed in the Declaration of Conformity statement in Chapter 2. The system also complies with the limits for Class B digital devices pursuant to Part 15 of the FCC rules, and it uses a power supply that is a UL recognized (ULR) component.

<sup>1</sup> Although the power supply is auto-switching, there are two separate models of the *VSL-337ND-S* to accommodate differences in utility receptacles:  
*Model 337201-00 accommodates 100-120 Vac, 50-60 Hz;*  
*Model 337201-01 accommodates 200-240 Vac, 50-60 Hz.*

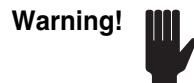

---

This user information is in compliance with section 1040.10 of the CDRH Laser Products Performance Standards from the Health and Safety Act of 1968. The use of controls or adjustments, or the performance of procedures other than those specified herein, may result in hazardous radiation exposure.

---



---

The Spectra-Physics *VSL-337ND-S* air-cooled nitrogen laser is a *Class IIIb—Medium Power Laser* whose beam is, by definition, a safety hazard. Take precautions to prevent accidental exposure to both direct and reflected beams. Diffuse as well as specular beam reflections can cause severe eye or skin damage. *The 337 nm UV output from the laser is invisible and, therefore, especially dangerous!*

---

This safety section should be reviewed thoroughly prior to operating the *VSL-337ND-S* laser system, and the safety precautions listed herein should be followed carefully.



---

The CE certification described in this chapter applies to standard models of the *VSL-337ND-S* air-cooled nitrogen laser. OEM versions of this laser will carry CE marking when appropriate for the specific model.

---

### Hazards

Hazards associated with the use of ultraviolet lasers generally fall into the categories listed below. At all times while working with these lasers, please be aware of these potential hazards and act accordingly. You are responsible for your health and the health of those working around you.

- Exposure to laser radiation can result in damage to the eyes or skin.
- Exposure to chemical hazards, such as laser generated airborne contaminants, can be health hazards when they are released as a result of laser material processing or as by-products of the lasing process itself. When these lasers are used to pump dye laser systems, be aware that the dyes used can be extremely hazardous to your health if inhaled or, in some cases, even touched.
- Exposure to high-voltage electrical circuits present in the laser power supply and associated circuits can result in shock or even death.
- Possible health risks are present if pressurized hoses, cylinders, liquids and gasses used in laser systems are damaged or misused.

## Precautions For The Safe Operation Of Class IIb Medium Power Lasers

- Wear protective eyewear at all times; selection depends on the wavelength and intensity of the radiation, the conditions of use, and the visual function required. Protective eyewear is available from suppliers listed in the *Laser Focus World*, *Lasers and Optronics*, and *Photonics Spectra* buyer's guides. Consult the ANSI and ACGIH standards listed at the end of this section for guidance.
- Maintain a high ambient light level in the laser operation area so the eye's pupil remains constricted, reducing the possibility of damage.
- To avoid unnecessary radiation exposure, keep the protective cover on the laser head at all times.
- Avoid looking at the output beam; even diffuse reflections are hazardous. And, because the beam is invisible, the laser can appear to be off even when it is not.
- Avoid blocking the output beam or its reflections with any part of the body.
- Establish a controlled access area for laser operation. Limit access to those trained in the principles of laser safety.
- Post prominent warning signs near the laser operating area (Figure 2-1).
- Set up experiments so that the laser beam is either above or below eye level.
- Provide enclosures for beam paths whenever possible.
- Set up shields to prevent any unnecessary specular reflections.
- Set up a beam dump to capture the laser beam and prevent accidental exposure (Figure 2-2).



**Figure 2-1: These CE and CDRH standard safety warning labels would be appropriate for use as entry warning signs (EN 60825-1, ANSI 4.3.10.1).**

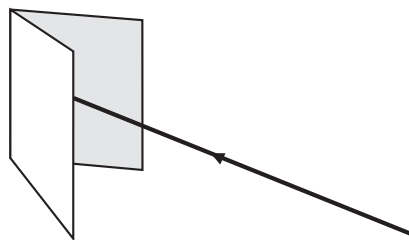

**Figure 2-2: Folded Metal Beam Target**



**Caution!**



Use of controls or adjustments, or performance of procedures other than those specified herein may result in hazardous radiation exposure.

**Danger!**



Operating this laser without due regard for these precautions or in a manner that does not comply with recommended procedures may be dangerous. At all times during installation, maintenance or service of your laser, avoid unnecessary exposure to laser or collateral radiation\* that exceeds the accessible emission limits listed in “Performance Standards for Laser Products,” *United States Code of Federal Regulations*, 21CFR1040.10(d).

Follow the instructions contained in this manual to ensure proper installation and safe operation of your laser.

## Maximum Emission Levels and Protective Eye Wear

It is recommended that laser-safe eye wear be worn at all times when the *VSL-337ND-S* nitrogen laser is on. The table below shows the maximum emission level possible for this product. Use this information for selecting appropriate laser safety eyewear and implementing appropriate safety procedures. This value does not imply actual system power or specifications.

Emission Wavelength	Maximum Power
337 nm – laser output wavelength	7.2 mW

During normal operation, the operator will not be exposed directly to other hazardous emissions. However, removing the mechanical housing cover during operation will not only invalidate the warranty, but will also expose the operator to hazardous radiation.

## Safety Devices

There are several safety devices on this laser. Figure 2-3 shows their locations. Each is described in detail below.

### ***Interlock Keyswitch***

The laser OFF/ON keyswitch provides interlock safety to prevent unauthorized personnel from using the system when the key is turned to the OFF position and the key is removed. Turning the key to the ON position closes the interlock and activates the laser. The key can only be removed when the switch is in the OFF position.

\* Any electronic product radiation, except laser radiation, emitted by a laser product as a result of or necessary for the operation of a laser incorporated into that product.

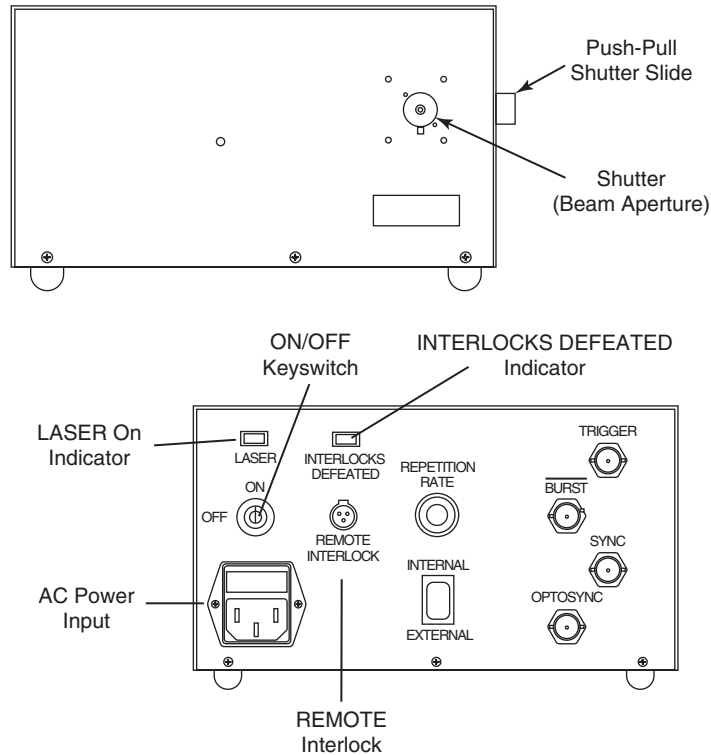

**Figure 2-3: The VSL-337ND-S laser, showing the location of the safety devices on the front (upper figure) and rear (lower figure) panels.**

**Emission and Power Indicator**

When the red LASER indicator is on, it means that ac power is applied to the unit and that laser radiation is present or imminent.

This indicator turns on 3 to 5 seconds before actual emission occurs.

**Shutter**

The mechanical shutter is hand operated by means of the push-pull slide on the front panel (Figure 2-3).

**Remote Interlock**

The REMOTE INTERLOCK allows the user to stop laser operation by the activation of a (user supplied) safety switch, such as a doorway entry switch. This connector is supplied with a connector jumper that must be installed if the interlock is not to be used. If the REMOTE INTERLOCK connector pins J<sub>1</sub> and J<sub>2</sub> are open, the laser will not operate.

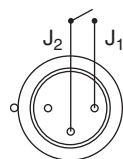

**Figure 2-4: Remote Interlock Connector**



When these pins are shorted, the current supplied through them is 24 mA. When the interlock connector is open, the voltage across them is 24 V maximum. Choose an appropriate switch for low-voltage, low-current service.

### **Interlocks Defeat Indicator**

When on, this green light (Figure 2-3) indicates all interlocks are closed and that the laser is ready to fire. If it is off, the laser will not operate.

### **External Trigger Connector**

It is possible to trigger this laser externally using a TTL-level signal supplied through the TRIGGER connector. Operating the laser in this fashion is explained in Chapter 6, “Operation.” The maximum allowable pulse rate is 30 Hz continuous, or up to 60 Hz in burst mode.



---

Even when the laser is *not firing*, the laser energy storage capacitor is usually charged, and the laser is waiting for a trigger signal. Since the laser is ready to be fired at any time, all precautions should be taken to avoid accidental laser exposure should the laser trigger unexpectedly.

---

### **Burst Input Connector**

A TTL-level signal applied to this connector sets the laser to “burst” mode as explained in Chapter 6, “Operation.” The maximum allowable pulse rate is 60 Hz in burst mode.

At low repetition rates, burst mode control allows the laser power supply to be disabled.

### **Cover Safety Interlock**

An interlock cover switch ensures that the *VSL-337ND-S* nitrogen laser cannot be operated if the external sheet metal cover is not in place. The switch is internal, located toward the rear of the unit (see Fig. 3-7). The laser should not be opened by the user except to change the plasma cartridge, and then only by someone trained in this procedure by Spectra-Physics.

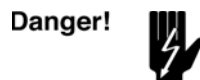

---

Do not operate the *VSL-337ND-S* nitrogen laser with its cover removed except when necessary during required service. Removing the cover may expose personnel to hazardous voltages and radiation. It also increases the rate of optical surface contamination.

---

## Maintenance Necessary to Keep this Laser Product in Compliance with Center for Devices and Radiological Health (CDRH) Regulations

This laser product complies with Title 21 of the *United States Code of Federal Regulations*, Chapter 1, subchapter J, parts 1040.10 and 1040.11, as applicable. To maintain compliance with these regulations, once a year, or whenever the product has been subjected to adverse environmental conditions (e.g., fire, flood, mechanical shock, spilled solvent, etc.), check to see that all features of the product identified on the CDRH Radiation Control Drawing (found later in this chapter) function properly. Also, make sure that all warning labels remain firmly attached.

1. Verify that removing the jumper from or, if implemented, opening the interrupt switch connected to the INTERLOCK connector on the laser control panel (Figure 2-1) prevents laser operation.
2. Verify that the laser can only be turned on when the keyswitch is in the ON position, and that the key can only be removed when the switch is in the off position.
3. Verify that the emission indicator(s) provides a visible signal when the laser emits accessible laser radiation that exceeds the accessible emission limits for Class I.\*
4. Verify the time delay between turn-on of the emission indicator(s) and the start of the laser; it must give enough warning to allow actioto avoid exposure to laser radiation.
5. Verify that the beam attenuator (mechanical shutter) actually blocks exposure to laser radiation.

If any of the above items fail to operate as noted and you cannot correct the error, please call your Spectra-Physics service representative for assistance. A list of service centers can be found in “Customer Service” at the end of this manual.

\* 0.39  $\mu$ W for continuous-wave operation where output is limited to the 400 to 1400 nm range.

## CE/CDRH Radiation Control Drawing

Refer to the CE/CDRH Warning Labels on the next page.

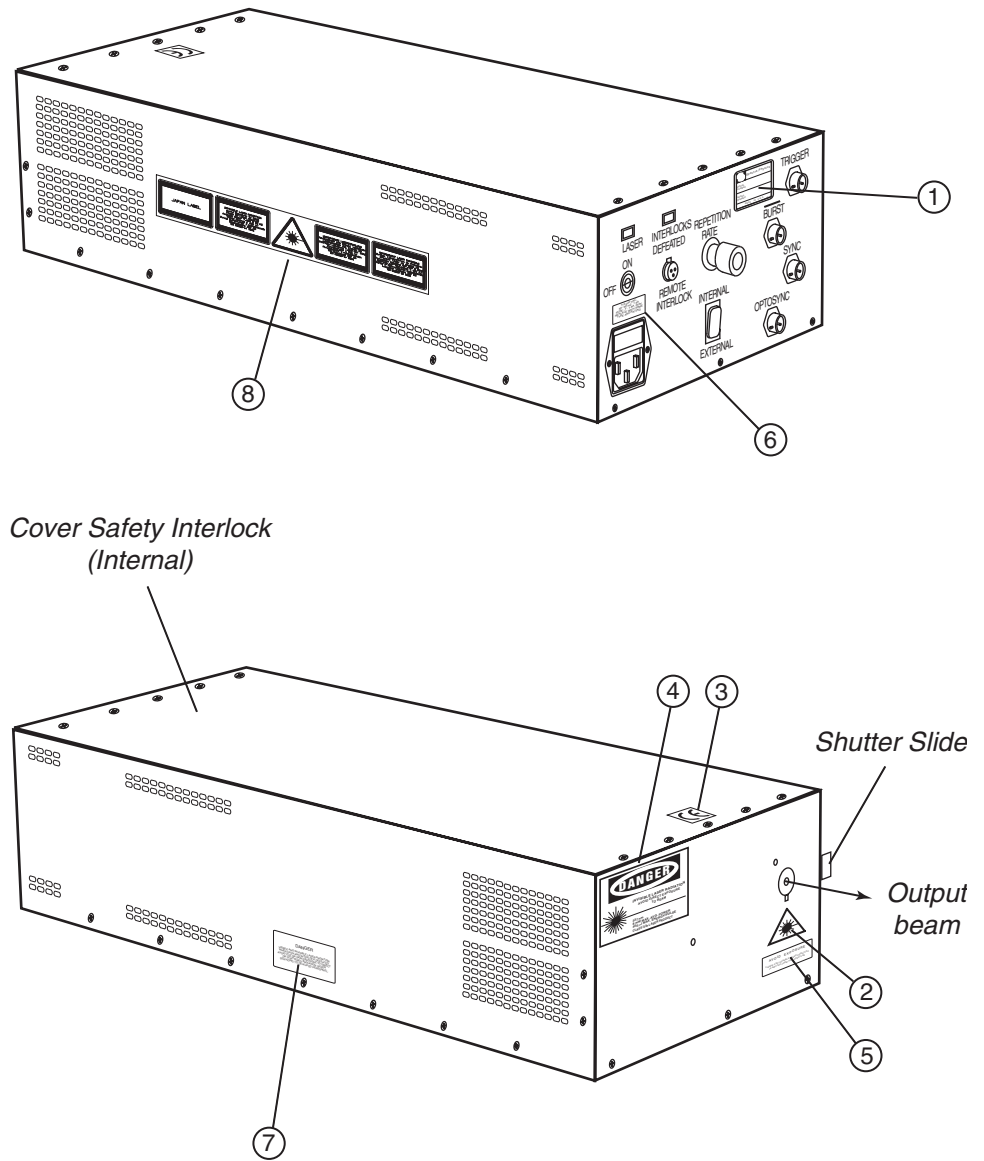
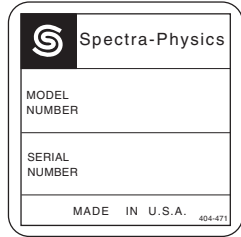

Figure 2-5: CE/CDRH Radiation Control Drawing

## CE/CDRH Warning Labels



Model/Serial Identification Label (1)



CE Aperture Label (2)

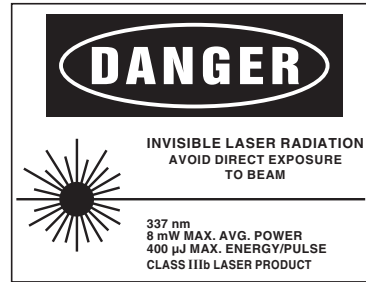

Danger Laser Radiation Label (4)



CE Certification Label (3)



Aperture Label (5)

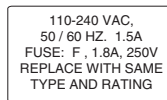

Fuse Label (6)



CE Interlocked Cover Label (7)

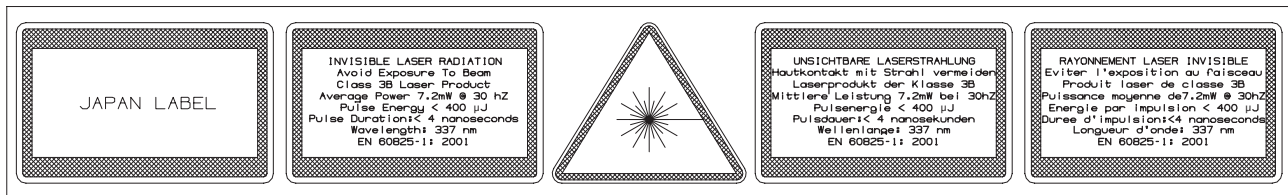

International CE Label (8)

### Internal Labels



Danger High Voltage Label



CE Electrical Warning Label



System Ground Label

Figure 2-6: CE/CDRH Warning Labels

## Label Translations

For safety, the following translations are provided for non-English speaking personnel. The number in parenthesis in the first column corresponds to the label number listed on the previous page.

**Table 2-1: Label Translations**

Label No.	French	German	Spanish	Dutch
Danger Laser Radiation Label (2)	Attention Rayonnement laser invisible. Exposition dangereuse au rayonnement direct ou diffus. 337 nm. Puissance moyenne de 8 mW. Energie maximum par impulsion 400 µJ. Appareil à laser de classe 3b.	Vorsicht Unsichtbare Laserstrahlung. Bestrahlung von Auge oder Haut durch direkte oder Streustrahlung vermeiden. 337 nm. Mittlere Leistung 8 mW. Maximale Pulsenergie 400 µJ. Laserklasse 3b.	Peligro Radiación láser invisible. Evitar la exposición directa o dispersa. 337 nm. Potencia máxima promedio 8 mW. Energía máxima del pulso 400 µJ. Producto láser Clase 3b.	Gevaar Onzichtbare laserstraling. Vermijd blootstelling aan ogen of huid door directe of gereflecteerde straling. 337 nm. Maximaal uitgedend vermogen 8 mW. Maximaal pulsenergie 400 µJ. Klasse 3b laser produkt.
Aperture Label (3)	Ouverture Laser - Exposition Dangereuse - Un Rayonnement laser visible et invisible est emis par cette ouverture.	Austritt von sichtbarer und unsichtbarer Laserstrahlung! Bestrahlung vermeiden!	Evite la exposición. Por esta abertura se emite radiación láser visible e invisible.	Vanuit dit apertuur wordt zichtbare en onzichtbare laserstraling geëmitteerd! Vermijd blootstelling!
CE Interlocked Cover Label (5)	Attention; Rayonnement Laser Visible et Invisible en Cas D'Ouverture et lorsque la securitc est neutralisée; Exposition Engereuse de l'œil ou de la Peau au Rayonnement Direct ou Diffus. Référez-vous l'entretien au personnel qualifié.	Vorsicht; beim Öffnen Austritt von sichtbarer und unsichtbarer Laserstrahlung wenn Sicherheitsverriegelung überbrückt; Bestrahlung von Auge oder Haut durch direkte oder Streustrahlung vermeiden. Wenden Sie sich mit Wartungsarbeiten an qualifiziertes Personal.	Peligro; Radiación láser visible e invisible existe al abrir el dispositivo de seguridad. Evite que los ojos y la piel queden expuestos a la radiación directa o dispersa. Refiera servicio solamente a personal calificado.	Gevaar; Zichtbare en onzichtbare laserstraling; vermijd blootstelling aan huid of oog aan disecte straling of weerkaatsingen.

## CE Declaration of Conformity

We,

Spectra-Physics  
1335 Terra Bella Avenue  
Mountain View, CA. 94043  
United States of America

declare under our sole responsibility that the following products:

**VSL-337ND-S-XXX**  
**(XXX are numbers that denote Customer Specific Models)**

manufactured after November 1, 2003,

meet the intent of “EMC Directive 89/336/EEC for Electromagnetic Compatibility” and “Directive 73/23/EEC, the Low Voltage Directive.” Compliance was demonstrated to the following Specifications as listed in the official *Journal of the European Communities*:

**89/336/EEC: 1989, EMC Directive**

**EN61326: 1997 + A1: 1998 + A2: 2000**, Electrical equipment for measurement, control and laboratory use - EMC requirements.

**EN 61000-3-2: 1995**, Electromagnetic compatibility (EMC) Part 3: Limits—Section 2: Limits for harmonic current emissions (equipment input current  $\leq 16$  A per phase).

**EN 61000-3-3: 1995**, Electromagnetic compatibility (EMC) Part 3: Limits—Section 3: Limitation of voltage fluctuation and flicker in low-voltage supply systems for equipment with rated current of  $\leq 16$  A.

**EN 61000-4-2: 1995**, Electromagnetic compatibility (EMC) Part 4: Testing and measurement techniques—Section 2: Electrostatic discharge immunity test.

**EN 61000-4-3: 1995**, Electromagnetic compatibility (EMC) Part 4: Testing and measurement techniques—Section 3: Radiated, radio frequency, electromagnetic field immunity test.

**EN 61000-4-4: 1995**, Electromagnetic compatibility (EMC) Part 4: Testing and measurement techniques—Section 4: Electrical fast transient/burst immunity test.

**EN 61000-4-5: 1995**, Electromagnetic compatibility (EMC) Part 4: Testing and measurement techniques—Section 5: Surge immunity test.

**EN 61000-4-6: 1996**, Electromagnetic compatibility (EMC) Part 4: Testing and measurement techniques—Section 6: Immunity to conducted disturbances, induced by radio frequency fields.

**EN 61000-4-11: 1994**, Electromagnetic compatibility (EMC) Part 4: Testing and measurement techniques—Section 11: Voltage dips, short interruptions and voltage variations immunity tests.

**73/23/EEC: 1973, Low Voltage Directive**

**EN60950: 1992, with Amendment 1:1993, Amendment 2:1994, Amendment 3: 1996, Amendment 4:1997, and Amendment 11:1997**, Safety of Information Technology Equipment, including electrical business equipment

**EN60825-1: 1993, with Amendments A1:1997 and A2:2001**, Safety of laser products- Part 1 Equipment classification, requirements, and users guide



Bruce Craig  
Vice President  
Spectra-Physics  
December 16, 2003

## Sources for Additional Information

The following are some sources for additional information on laser safety standards, safety equipment, and training.

### ***Laser Safety Standards***

*Safe Use of Lasers* (Z136.1: 1993)  
American National Standards Institute (ANSI)  
11 West 42<sup>nd</sup> Street  
New York, NY 10036  
Tel: (212) 642-4900

Occupational Safety and Health Administration (Publication 8.1-7)  
U. S. Department of Labor  
200 Constitution Avenue N. W., Room N3647  
Washington, DC 20210  
Tel: (202) 693-1999

*A Guide for Control of Laser Hazards*, 4th Edition, Publication #0165  
American Conference of Governmental and  
Industrial Hygienists (ACGIH)  
1330 Kemper Meadow Drive  
Cincinnati, OH 45240  
Tel: (513) 742-2020  
Internet: [www.acgih.org/home.htm](http://www.acgih.org/home.htm)

Laser Institute of America  
13501 Ingenuity Drive, Suite 128  
Orlando, FL 32826  
Tel: (800) 345-2737  
Internet: [www.laserinstitute.org](http://www.laserinstitute.org)

Compliance Engineering  
70 Codman Hill Road  
Boxborough, MA 01719  
Tel: (978) 635-8580

International Electrotechnical Commission  
*Journal of the European Communities*  
EN60825-1 TR3 Ed.1.0—Laser Safety Measurement and Instrumentation  
IEC-309—Plug, Outlet and Socket Coupler for Industrial Uses  
Tel: +41 22-919-0211  
Fax: +41 22-919-0300  
Internet: <http://ftp.iec.c.h/>

Cenelec  
European Committee for Electrotechnical Standardization  
Central Secretariat  
rue de Stassart 35  
B-1050 Brussels

Document Center  
1504 Industrial Way, Unit 9  
Belmont, CA 94002-4044  
Tel: (415) 591-7600

## ***Equipment and Training***

### *Laser Safety Guide*

Laser Institute of America  
12424 Research Parkway, Suite 125  
Orlando, FL 32826  
Tel: (407) 380-1553

### *Laser Focus World Buyer's Guide*

Laser Focus World  
Penwell Publishing  
10 Tara Blvd., 5<sup>th</sup> Floor  
Nashua, NH 03062  
Tel: (603) 891-0123

### *Lasers and Optronics Buyer's Guide*

Lasers and Optronics  
Gordon Publications  
301 Gibraltar Drive  
P.O. Box 650  
Morris Plains, NJ 07950-0650  
Tel: (973) 292-5100

### *Photonics Spectra Buyer's Guide*

Photonics Spectra  
Laurin Publications  
Berkshire Common  
PO Box 4949  
Pittsfield, MA 01202-4949  
Tel: (413) 499-0514



## A Brief Review of Laser Theory

### *Emission and Absorption of Light\**

*Laser* is an acronym derived from Light Amplification by Stimulated Emission of Radiation. Radiant emission and absorption take place within the arrangement of the electrons in the atomic or molecular structure of materials. Each electron occupies a unique orbital that has a distinct energy (Figure 3-1). Together, the energies of the electrons in their orbitals make up the energy state of an isolated atom.

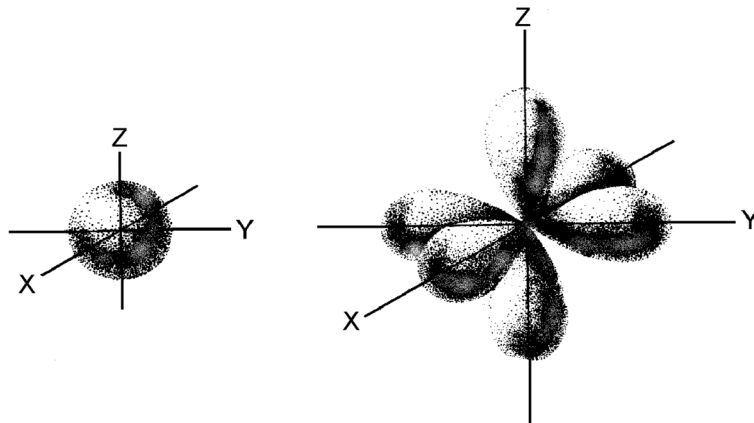

**Figure 3-1: Electrons occupy distinct orbitals in an atom or molecule. Two different distributions are shown.**

The level with the lowest possible energy at a given temperature is the ground state, in which each electron is in the least energetic orbital available to it. Higher energy levels are called excited states, where some electrons occupy orbitals farther from the nucleus.

The same considerations are also true of molecules, with the additional complication that the individual atoms are in motion relative to their molecular partners. A molecule has different modes of vibration and rotation, depending on its shape. If a molecule changes its vibrational or rotational mode, the distribution of its electrons will also change.

\* “Light” will be used to describe the portion of the electromagnetic spectrum from far infrared to ultraviolet.

A transition from one energy level to another happens when the atom or molecule either absorbs or emits energy. Upward transitions can be caused by collisions with electrons or other atoms or molecules, or by the absorption of a photon. A transition from a lower level  $E_1$  to a higher one,  $E_2$  will only occur if the energy of the absorbed photon matches the energy difference between levels, i.e.

$$h\nu = E_2 - E_1 \quad [1]$$

where  $h$  is Planck's constant, and  $\nu$  is the frequency of the photon.

Likewise, when an atom excited to  $E_2$  decays to  $E_1$ , it loses energy equal to  $E_2 - E_1$ . The atom may decay spontaneously, emitting a photon with energy  $h\nu$  and wavelength  $\lambda$  where

$$\lambda = \frac{hc}{E_2 - E_1} \quad [2]$$

An atom excited to  $E_2$  can also be stimulated to decay to  $E_1$  by interacting with a photon of frequency  $\nu$ , which is perhaps produced by the spontaneous emission from a neighboring atom. This stimulated decay emits a pair of new photons that are identical to the absorbed one in phase, frequency, and direction. This is known as stimulated emission. In contrast, spontaneous emission produces photons that have no directional or phase relationship with one another.

### **Population Inversion**

The net absorption is the difference between the rates of emission and absorption. The rate of excitation from  $E_1$  to  $E_2$  is proportional to the number of atoms in the lower level ( $N_1$ ). Similarly, the rate of stimulated emission is proportional to the population of the upper level ( $N_2$ ). When a material is at thermal equilibrium, most of its molecules are in the ground state. The rate of absorption of photons exceeds that of emission, with most of the absorbed energy dissipated in heating the material.

If enough light of frequency  $\nu$  is supplied, the populations can be shifted until  $N_1 = N_2$ . Under these conditions the rates of absorption and stimulated emission are equal, and the absorption coefficient at frequency  $\nu$  is zero. If the transition scheme is limited to two energy levels,  $N_2$  can never exceed  $N_1$  because every upward transition is matched by one in the opposite direction.

However, if three or more energy levels are employed, it is possible to create a population inversion where  $N_2 > N_1$ .

A model four-level laser transition scheme is depicted in Figure 3-2. A photon of frequency  $\nu_1$  excites an atom from  $E_1$  to  $E_4$ —for example, the absorption of the photon causes one of the electrons of the atom to move to a higher energy orbital. If the electron prefers to decay to  $E_3$  rather than  $E_1$ , and if its lifetime at  $E_4$  is short, the atom will decay almost immediately to  $E_3$ . If  $E_3$  is metastable, i.e., atoms that occupy  $E_3$  have a relatively long lifetime, the population will grow rapidly as excited atoms cascade from above.

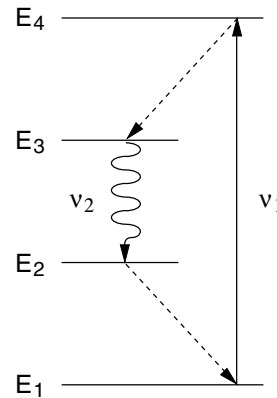

**Figure 3-2: A typical four-level transition scheme**

For many materials, the atom can decay to  $E_2$  by stimulated emission of a photons of frequency  $\nu_2$ . Note, however, that the atom can also be re-excited to  $E_3$  by the absorption of a photon of the same energy. However, if  $E_2$  atoms return rapidly to the ground state,  $E_1$ , the population of  $E_2$  is kept small and the rate of absorption of  $\nu_2$  is reduced.

In this way the population of  $E_3$  is kept large and that of  $E_2$  remains low, thus establishing a population inversion between  $E_3$  and  $E_2$ . Under these conditions, light is amplified as it is emitted by one excited atom, encounters another where it stimulates emission, which stimulates emission of other excited atoms, and so on. The greater the population inversion, the greater the amplification or gain.

The dynamics of lasing action depends in a critical way on the relative lifetimes of the energy levels. For example, if the  $E_2$  level is slow to empty, that is, if it has a lifetime that is relatively long compared to the upper laser level  $E_3$ , its population will soon exceed that of  $E_3$  and laser action will be extinguished. However, if a mechanism can be devised to quickly excite the higher levels, transitory or pulsed laser amplification may be possible.

This in fact is the case with the nitrogen laser. The lower laser level is slow to decay, so the population inversion is only sustainable for a few nanoseconds. However a fast pulse of high voltage discharge is capable of exciting a large number of molecules to the upper level quickly enough so that an inversion is possible.

### ***Nitrogen as a Laser Medium***

The nitrogen laser transition takes place between energy levels of the  $N_2$  nitrogen molecule. Each mode of vibration of the molecule interacts with the orbitals, causing many new and closely spaced levels to become available to the electrons. Electrons are excited to a range of upper energy levels in one mode of vibration of the molecule, and decay to a range of electronic levels in a lower energy vibrational mode.

Both the internal vibration of the molecular atoms and the energies of their electrons change simultaneously in what is called a “vibronic” transition.

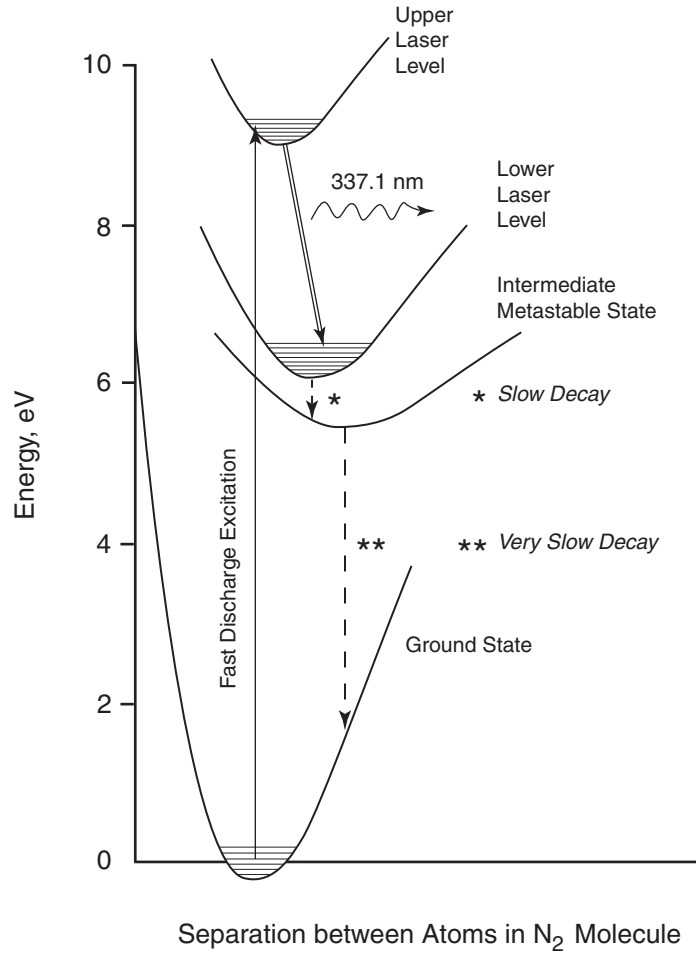

**Figure 3-3: The long lifetimes of the lower molecular energy levels are responsible for the pulsed nature of the nitrogen laser output.**

### The Optical Cavity

Lasers with relatively modest gain use a resonant optical cavity to pass the light back and forth through the gain medium a number of times sufficient to overcome absorption and internal losses. As with other amplifiers, the signal strength, in this case the light intensity, increases until it reaches a steady state condition where the gain saturates (becomes unity).

The resonant optical cavity is most often two mirrors that reflect light that is parallel to the cavity axis through the gain medium. Both cavity mirrors are coated to reflect the wavelength of interest while transmitting all others. One of the mirrors, the output coupler, transmits a fraction of the energy circulating within the cavity, which becomes the output beam of the laser.

The situation changes when the gain of the laser medium is very high, as it is for nitrogen lasers. In the limiting case of super-radiance, no resonant cavity is necessary at all, as the device will produce laser light with a single pass through the nitrogen gas discharge. It is typical of these types of lasers, which include semiconductor lasers, to produce a beam of comparatively lower spatial and spectral quality.

The mechanism that excites the gain often plays an important role in the shape of the laser beam in such devices as it forms a profile within the gain medium where laser light is produced. This usually requires that extra measures be taken in the design of these lasers to create a beam of sufficiently useful quality. Often the cavity mirrors provided are as much to shape the beam output as to enhance the amplification mechanism.

The shape of the laser output beam is very much dependent on the frequency content of the beam. This is determined by the width of the gain in frequency space around the transition frequency, and by the design of the optical cavity. The optical cavity supports a number of standing waves, modes of the kind found in waveguides for RF systems. Each mode has a different cross section and frequency. The output beam is a superposition of the cross sections of these modes for its spatial character, and of the mode frequencies for its spectral content.

For applications seeking maximum output power, a cavity design that results in the creation of a number of these “spatial” or higher-order modes is used so that the laser beam within the gain medium overlaps most of the volume of the excited molecules. The optical design of the cavity must also produce a beam that allows the useful application of its power, with characteristics such as a smooth profile and a low divergence.

The duration, or “pulse width” of the output is specified by plotting amplitude as a function of frequency and measuring the width of the curve where the output has fallen to one half its maximum value (“full width at half maximum” or FWHM). As might be expected, the spectral content of high gain laser pulses is relatively broad.

## The VSL-337ND-S Nitrogen Laser

The major components of the laser are shown in Figure 3-4.

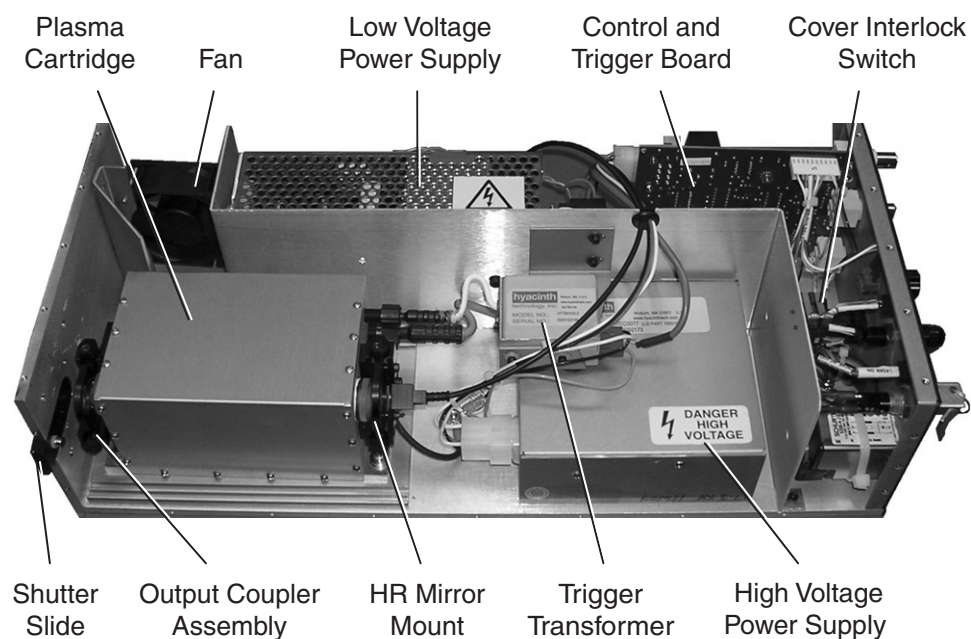

**Figure 3-4: VSL-337ND-S Internal Components**

### Output Pulse

The *VSL-337ND-S* nitrogen laser is designed specifically for generating ultraviolet (UV) pulses at 337 nm that have very low angular beam divergence, without compromising their high pulse energy. The full beam divergence angle is less than 0.3 mrad. This is accomplished by placing the gain medium, the nitrogen plasma tube, between specially designed mirrors of an optical cavity. In addition to increasing the efficiency of light output, the optical cavity optimizes beam quality.

Population inversion is achieved through a high-voltage discharge that is transverse to the axis of the output beam. The pulsed discharge is applied in the nanosecond time scale needed to match the lifetime of the nitrogen laser transition. The characteristics of the nitrogen gas at the low pressure used in the *VSL-337ND-S* result in output pulses typically greater than 300 microjoules in energy and less than 4 nanoseconds in duration, and that can be repeated at rates of up to 30 Hz in a continuous duty cycle (Figure 3-5).

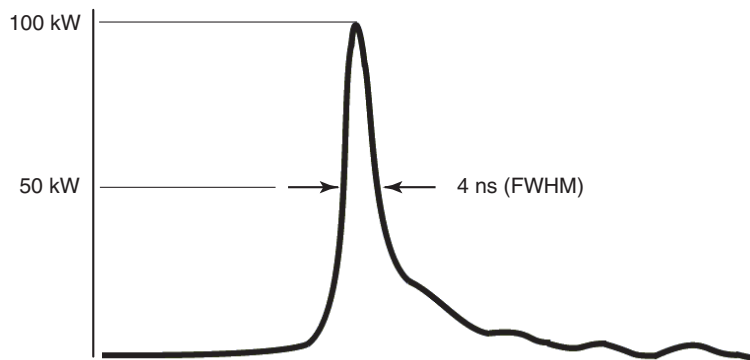

Figure 3-5: Typical output pulse, *VSL-337ND-S*

### Beam Cross Section

Before any appreciable divergence occurs, the cross section of the output of the *VSL-337ND-S* is a square, 7 mm on a side, with a smaller square cut out of one of its corners that is about 3 mm x 3 mm, as shown in Figure 3-6.

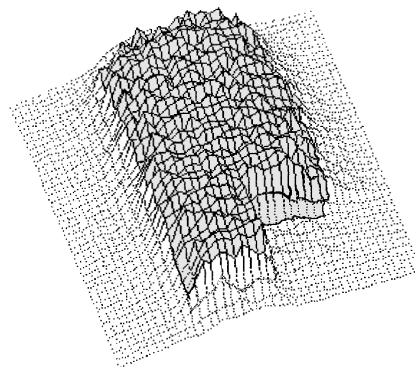
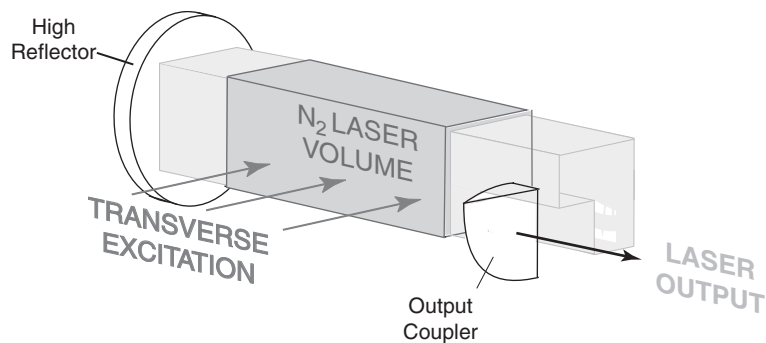

Figure 3-6: Typical profile of the *VSL-337ND-S* laser beam

This beam shape is determined by the approximately square cross section of the transverse electrical discharge, combined with the blocking effect caused by the “output coupler” mirror of the optical cavity (Figure 3-7).



**Figure 3-7: A representation of the VSL-337ND-S laser cavity**

This mirror is a 90° circular segment with a convex surface oriented towards the plasma tube. The mirror segment intercepts, with its 90° edge, a fraction of the laser beam (~20%) in order to supply the optical feedback into the amplifying medium (that is, the nitrogen gas discharge in the plasma tube).

Actually, it is not the convex mirror, but the lack of this mirror surface that allows the beam to exit from the optical cavity. The concave high reflector at the rear of the cavity prevents the loss of about half the laser energy that would occur in its absence.

### **High Voltage Power Supply**

The performance of any nitrogen laser is critically dependent on its power supply, which must be capable of switching > 15 kV with a very fast rise time. The VSL-337ND-S power supply consists of a 38 kHz switching module that charges a parallel capacitor to about 17 kV. The supply fully charges the capacitor within about 15 milliseconds. This capacitor voltage is held off by the nitrogen tube itself, which acts as an insulator until the gas discharge is initiated by a spark-gap transformer, triggered either internally or externally to pre-ionize the gas. At this point the capacitor fires, fully discharging and ionizing the nitrogen gas in less than a few nanoseconds.

After the laser has fired, the power supply is prevented from immediately recharging the capacitor. This minimizes the possibility that, in certain conditions, the laser will prematurely emit a pulse before receiving a trigger signal. Although rare, this spontaneous pulse emission can occur when the nitrogen gas is pre-ionized by some random event, and then can no longer hold off the fully charged capacitor, thus causing the laser to fire prematurely.

The duration of this recharge delay varies by operating mode. For internal triggering, the power supply does not begin a recharge cycle until 1 ms before it is required to prepare for the next laser pulse. For external triggering, the power supply is delayed from recharging the capacitor for approxi-

mately 2 ms after a pulse. The external triggering delay can be controlled using Burst Mode. Refer to Chapter 6 for more information.

The duty cycle of the power supply is limited by the characteristics of the nitrogen laser excitation. There is no advantage to building (or paying for) a power supply that can exceed the maximum repetition rate of the pulsed laser output. Thus, the upper limit of charging performance is 15 ms.

## **Trigger Control**

The laser may be triggered internally or externally. The REPETITION RATE knob on the rear control panel provides internal pulse rate adjustment between 0 to 30 Hz. External trigger control is available through the TRIGGER connector on the control panel, which accepts TTL pulses with a rising edge from 100 ns to 1 ms, and triggers a laser pulse less than 700 ns later.

### **Burst Mode**

By using the BURST input to reduce the duty cycle, the *VSL-337ND-S* can be operated at a repetition rate as high as 60 Hz. This input signal also provides a flexible means of controlling laser output in a variety of ways, including the gating of pulses in a grouped output and reducing power supply noise. Input is a TTL-level signal.

Burst mode functions by controlling the charging timing of the power supply. In this sense, Burst mode over-rides the trigger signal, suppressing the signal when the BURST signal is TTL “high.” Burst mode operates with both internal and external triggering. See Chapter 4 and Chapter 6 for detailed descriptions and examples.

## **Output Synchronization**

### **Sync Output**

A standard TTL rising-edge signal, derived from the trigger signal, is available to synchronize the timing of applications to the pulsed laser output. See Table 3-2 for characteristics of the TTL output pulses.

### **OptoSync Output**

A degree of delay and jitter between the trigger signal and the onset of ionization is inherent in producing a rapid high-voltage gas discharge. As a result, the interval between the trigger signal and the output of a laser pulse has a degree of unpredictability that may pose difficulty for some applications. These effects may be minimized using the high-speed TTL sync output from the OPTOSYNC connector, which is in extreme coincidence with the laser output pulse.

The OptoSync signal is derived from the detection of the laser pulse at the rear mirror of the laser cavity, and it follows the laser output pulse by less than 50 ns. The temporal jitter between the two is specified as less than 1 ns, but is typically less than 500 ps.



Since an OptoSync trigger pulse comes *after* a laser output pulse, it may be necessary to introduce a delay in the data collection system to make the best use of this feature. See Chapter 4 and Chapter 6 for further discussion and examples. The OptoSync output signal is available in both internal and external trigger modes.

## Specifications

**Table 3-1: VSL-337ND-S Nitrogen Laser Output Characteristics<sup>1</sup>**

<b>Wavelength</b>	337.1 nm
<b>Spectral bandwidth</b>	0.1 nm
<b>Repetition rate<sup>2</sup></b>	continuous operation: 0–30 Hz Burst Mode: 0–60 Hz
<b>Pulse width (FWHM)</b>	< 4 ns
<b>Pulse energy (typical)</b>	> 300 $\mu$ J
<b>Pulse-to-pulse energy stability (10 Hz)</b>	< 4%, standard deviation
<b>Peak power</b>	> 75 kW
<b>Average power (30 Hz)</b>	> 7.2 mW
<b>Polarization</b>	unpolarized
<b>Beam size (area)</b>	35 mm <sup>2</sup>
<b>Beam divergence (full angle)</b>	< 0.3 mrad

<sup>1</sup> Due to our continuous product improvement program, specifications are subject to change without notice.

<sup>2</sup> Burst Mode operates at reduced duty cycles, depending on the repetition rate. See Chapter 6 for details.

**Table 3-2: Trigger Specifications and Characteristics<sup>1</sup>**

<b>External trigger input<sup>2</sup></b>	TTL, rising edge trigger
<b>pulse width</b>	100 ns to 1 ms
<b>optical pulse delay</b>	< 1000 ns
<b>optical pulse temporal jitter</b>	< 40 ns, standard deviation
<b>OptoSync output<sup>3</sup></b>	TTL, rising edge trigger
<b>drive impedance</b>	50 $\Omega$
<b>pulse width</b>	10 $\pm$ 1 $\mu$ s
<b>optical pulse temporal jitter</b>	< 1 ns, standard deviation
<b>optical pulse delay</b>	$\leq$ 50 ns
<b>Sync output<sup>3</sup></b>	TTL, rising edge trigger
<b>pulse width</b>	10 $\pm$ 1 $\mu$ s
<b>optical pulse temporal jitter</b>	< 1 ns, standard deviation
<b>Burst input<sup>2,3</sup></b>	TTL: HI: disable laser firing LO (or float): enable laser firing

<sup>1</sup> Due to our continuous product improvement program, specifications are subject to change without notice.

<sup>2</sup> Optoisolated input

<sup>3</sup> Available in both internal and external modes

**Table 3-3: Mechanical and Electrical Specifications**

<b>AC power input</b>	100 to 240 Vac $\pm$ 10%, 50/60 Hz, single phase
<b>Power requirements</b>	1.5 A @ 110 Vac 1.0 A @ 220 Vac
<b>Size (W x H x L)</b>	46.2 x 19.4 x 11.7 cm (18.2 x 7.6 x 4.6 in.)
<b>Weight</b>	7.3 kg (16 lb)
<b>Air flow</b>	24 CFM
<b>Environmental operating temperature</b>	4–40°C (40–105°F)

**Table 3-4: Fuse Rating**

<b>Supply Voltage</b>	<b>Rating</b>	<b>Type</b>
100–240 Vac, 50/60 Hz	1.8 A	F 250 V

***Replaceable Plasma Cartridge***

The *VSL-337ND-S* features a Spectra-Physics user-replaceable plasma cartridge, that allows the user to regain the performance of a new laser at a fraction of the cost. The patented design ensures minimal downtime because no alignment of the laser cavity is necessary to return it to fully specified performance. The plasma cartridge is warranted to maintain at least 70% of the listed energy value (i.e., 210  $\mu$ J) for 20 million pulses or two years, whichever comes first.

### Outline Drawing

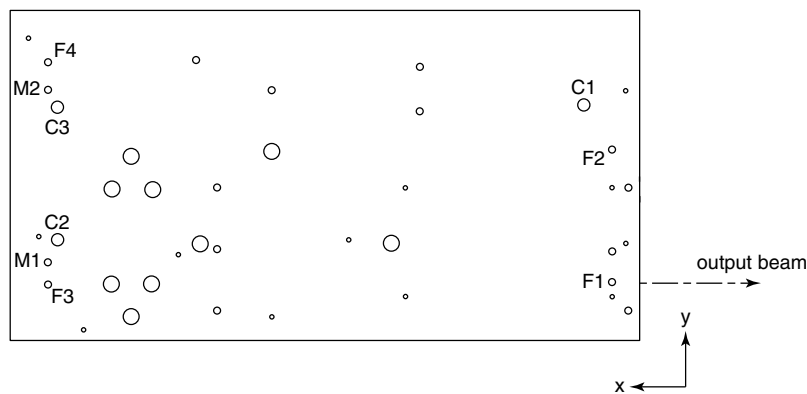
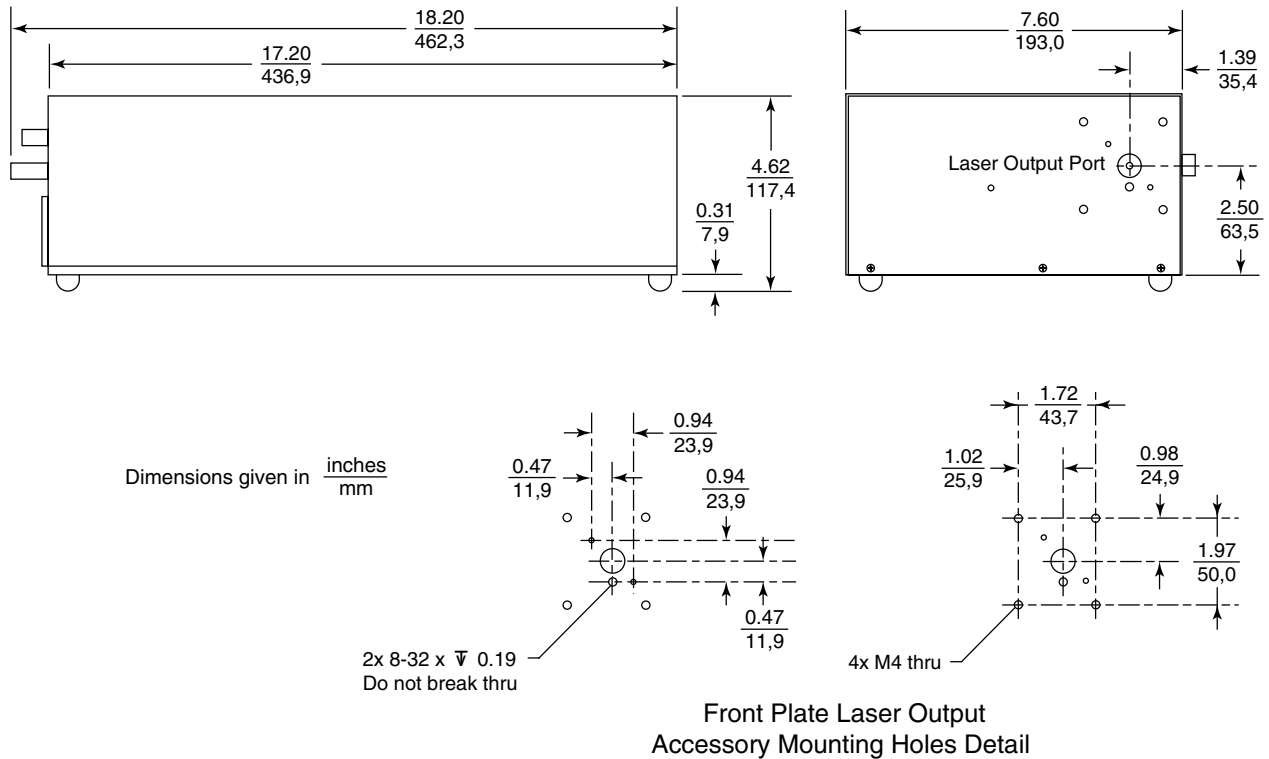

Base Plate Dimensions

hole	size	position (inches)		position (mm)	
		x	y	x	y
C1		1.50	5.32	38,1	135,1
C2	0.28 in.	15.50	2.32	393,7	58,9
C3		15.50	5.32	393,7	135,1
F1		0.75	1.32	19,1	33,5
F2	$\frac{1}{4}$ x 20	0.75	4.32	19,1	109,7
F3		15.75	1.32	400,1	33,5
F4		15.75	6.32	400,1	160,5
M1	M6	15.75	1.78	400,1	45,2
M2		15.75	5.72	400,1	145,3

Only the indicated holes are suitable for mounting the laser. The use of other holes in the base plate for mounting may result in loss of performance or damage to the laser.

Figure 3-8: Outline Drawing for the VLS-337ND-S Laser



## Front Panel

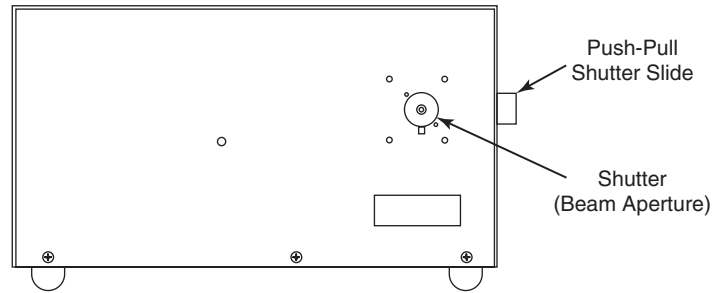
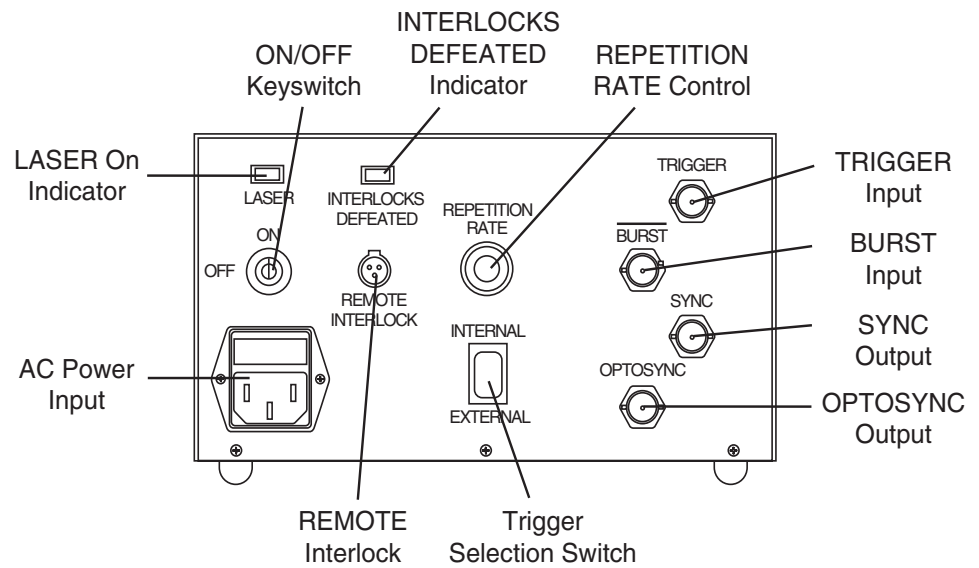

**Figure 4-1: VSL-337ND-S Front Panel**

## Controls

**Shutter**—is hand operated by means of the push-pull slide on the side.

## Rear Panel



**Figure 4-2: VSL-337ND-S Rear Control Panel**

## Controls

**Laser OFF/ON interlock keyswitch**—provides interlock safety to prevent unauthorized personnel from using the system when the key is turned to the OFF position and the key is removed. Turning the key to the ON position closes the interlock and activates the laser after a 3 to 5 second delay.

The key can only be removed when the switch is in the OFF position.

**REPETITION RATE knob**—controls the repetition rate of the pulsed laser output from 0 to 30 Hz when the INTERNAL/EXTERNAL trigger selection switch is set to INTERNAL.

**INTERNAL/EXTERNAL trigger selection toggle switch**—controls the repetition rate of the laser through the Repetition Rate knob when it is in the INTERNAL position. When in the EXTERNAL position, the repetition rate is controlled by an external TTL trigger signal applied to the TRIGGER connector.

## Indicators

**LASER emission indicator (red)**—shows that power is supplied to the laser and that laser emission is present or imminent. This indicator turns on 3 to 5 seconds before actual emission occurs.

**INTERLOCKS DEFEATED indicator (green)**—indicates the laser is ready to fire, i.e., that all the interlocks are closed.

## Connections

**TRIGGER connector (BNC)**—provides control of the pulsed laser output from an externally applied TTL trigger signal. A laser pulse is fired on the rising edge of a TTL pulse (rise time from 100 ns to 1 ms). The maximum allowable pulse rate is 30 Hz continuous, or up to 60 Hz when combined with the BURST input.



---

Even at low repetition rates, the energy storage capacitor is usually charged and the laser is ready for a trigger signal. Since the laser is ready to be fired at any time, precautions should be taken to avoid accidental exposure should the laser trigger unexpectedly.

---

To operate the *VSL-337ND-S* using an external trigger source, place the trigger selection switch in EXTERNAL and apply an positive-edge triggered TTL pulse  $\geq 1 \mu\text{s}$ . The laser output pulse is emitted  $\leq 1000 \text{ ns}$  later, with temporal jitter about this mean of 7 ns or less.

The maximum allowable pulse rate is 30 Hz when the laser is operated continuously. For higher repetition rates, refer to the BURST connector below. To minimize EMI/RF interference, an opto-isolator is used to protect the trigger input.

**REMOTE INTERLOCK connector (3-pin)**—allows the user to stop laser operation by activating (opening) a user-supplied safety switch, such as a doorway entry switch. The system is provided with a shorting jumper

installed on this connector that must be left in place if the interlock is not used. However, it can be replaced with a similar plug to wire to a normally closed relay or switch. Only two pins are used (Figure 4-3).

When pins  $J_1$  and  $J_2$  are shorted, the current flowing through them is 24 mA. When these pins are open, the voltage across them is 24 V maximum. If a switch is used, it must be certified for low-voltage, low-current operation. If the pins are not shorted, the laser will not operate.

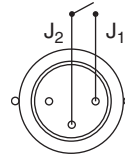

**Figure 4-3: Remote Interlock Connector**

**BURST input connector (BNC)**—is used to allow the laser to output bursts of pulses at repetition rates from 30 Hz to 60 Hz by reducing the duty cycle so that the laser is not damaged.

The BURST TTL input signal over-rides the trigger signal, whether triggering is internal or external and modifies the laser duty cycle by controlling the charging of the high-voltage power supply (HVPS). When BURST is low (or floating), laser operation and triggering proceeds normally (no bursts). When BURST is TTL high, the HVPS is prevented from charging.

This feature is useful for “gating” the output of the laser, whether triggered internally or externally, into separate groups of pulses with a user-specified interval between groups of pulsed output. Another use of the BURST port is to selectively control when the HVPS is allowed to recharge after the previous laser pulse. This is helpful in applications requiring low noise, where the switching frequency of the HVPS might cause problems.

Burst mode can also be used in a number of different configurations that have separate requirements for internal or external triggering. See Chapter 5 for more details on these and other Burst mode functions.

**SYNC output connector (BNC)**—provides a TTL rising-edge signal derived from the trigger pulse to allow the user to synchronize individual laser pulses to an application or experiment. This output is available with either internal or external triggering. Unlike the OptoSync signal (see below), the SYNC signal is produced simultaneously with the trigger pulse, so that the laser output pulse follows the SYNC output  $\leq 1000$  ns later.

When the *VSL-337ND-S* is triggered internally, SYNC provides a simultaneous TTL output pulse that is  $10 \mu\text{s}$  ( $\pm 1 \mu\text{s}$ ) in duration to allow synchronization of an application or experiment to individual laser pulses. For external triggering, SYNC output provides a buffered version of the external trigger input to allow “daisy-chaining” of the trigger signal to other systems.

**OPTOSYNC output connector (BNC)**—provides the preferred means of synchronizing applications and experiments to the pulsed laser output, when feasible. Unlike the SYNC signal (see above), the OPTOSYNC signal is derived from the actual detection of the laser pulse, and operates at a high degree of temporal coincidence with the actual laser output. However,

also unlike the SYNC output signal, the OPTOSYNC signal *follows* the emission of the laser pulse. Consequently, in order to make good use of OptoSync, it is usually necessary to produce an artificial delay in data collection.

A degree of delay and jitter are inherent in producing a rapid high-voltage gas discharge. These effects can be minimized using the OptoSync signal, a high-speed TTL sync low-jitter output signal, 10  $\mu\text{s}$  ( $\pm 1 \mu\text{s}$ ) in duration, that is in extreme coincidence with the laser output pulse. The detection of the laser pulse is by a photodiode at the rear mirror of the laser cavity.

The delay between the laser output pulse and the OPTOSYNC signal is specified as  $< 50 \text{ ns}$ , while the temporal jitter between the two is specified as  $< 1 \text{ ns}$  and is typically  $< 500 \text{ ps}$ . The OptoSync signal is available in both internal and external trigger modes, and it has TTL 50 drive capability. Examples of employing the OptoSync feature are given in Chapter 5.

The relationship between the triggering of the laser (either internal or external), the production of a laser output pulse, and the resulting production of an OptoSync pulse is shown in Figure 4-4. An oscilloscope representation shown in Figure 4-5.

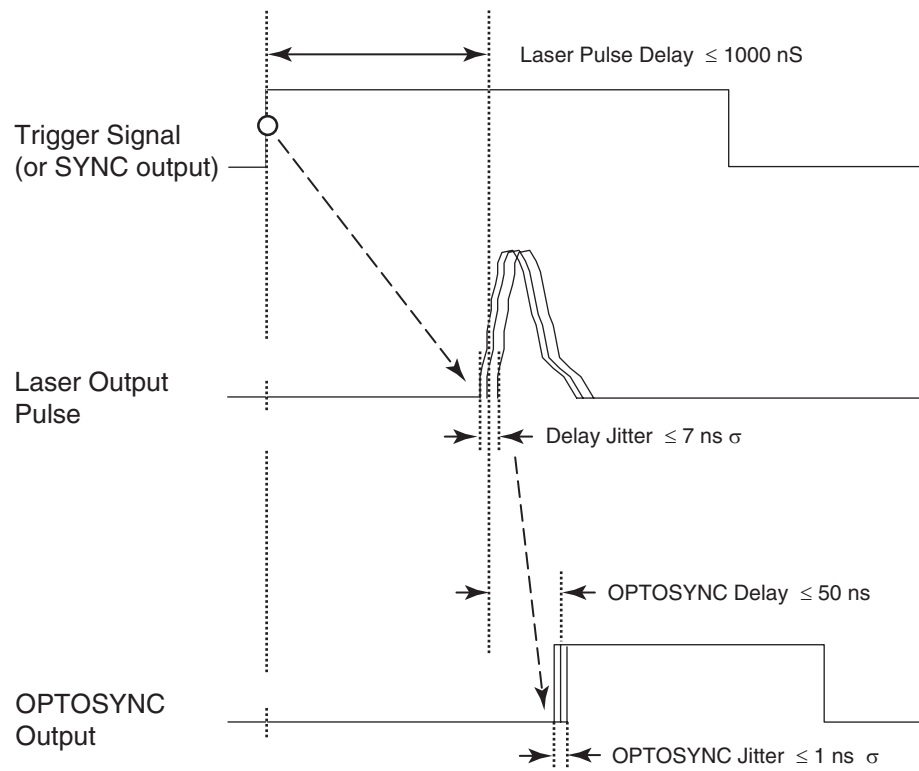

**Figure 4-4: The timing between the trigger signal, the laser pulse, and OPTOSYNC output.**



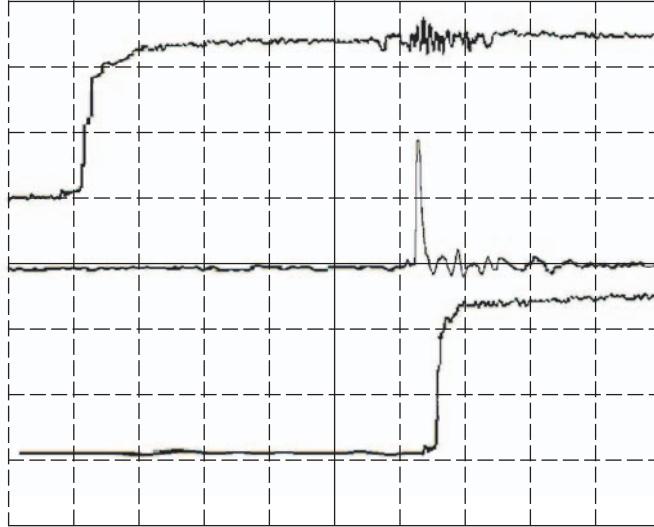

**Figure 4-5: Oscilloscope trace of the trigger pulse, the laser pulse, and OPTOSYNC output.**

**AC power connector**—provides attachment for an IEC ac power cable to the internal power supply. Although the power supply itself is auto-switching, there are two separate models to accommodate power receptacles for different utility service.

Model 33201-00 accommodates 1.5 A at 100–120 Vac, 50–60 Hz.

Model 33201-01 accommodates 1.0 A at 200–240 Vac, 50–60 Hz.



## Precautions



---

Please read this entire chapter and Chapter 2 on laser safety before using your laser for the first time.

The Spectra-Physics *VSL-337ND-S* laser is a *Class IIIb—Medium Power Laser* whose beam is, by definition, a safety and fire hazard. Take precautions to prevent accidental exposure to both direct and reflected beams. Diffuse as well as specular reflections of the invisible ultraviolet radiation can cause severe eye or skin damage.

Note that, at low pulse repetition rates, the laser is fully charged and ready to fire a considerable time before the arrival of a trigger pulse. Although unlikely, it is possible that some perturbation—electrical noise or perhaps a cosmic ray particle—may trigger the laser to emit a pulse spontaneously during this time. (See the descriptions and examples of Burst mode for suggestions on how to minimize this possibility.) So, for safety, treat the laser as though it is constantly emitting pulses whenever it is on.

In addition, note that whenever the laser is fully charged, changing from external to internal triggering or vice-versa produces a laser output pulse. It is recommended that the laser first be shut down, or the shutter be closed, before changing the trigger mode.

---

## Basic Operation

After plugging in the ac power cord, the most direct method of operating the laser is to use Internal mode as follows:

1. Close the shutter.
2. Set the Trigger Selection switch to INTERNAL.
3. Turn the keyswitch to ON. Laser emission will begin in 3 to 5 seconds.
4. Open the shutter. Fluorescence from the pulsed UV output is readily visible on a sheet of white paper.
5. Adjust the Repetition Rate control knob to the desired pulse frequency.
6. Turn off the laser by turning the keyswitch to the OFF position.

## Burst Control

Applying a TTL input to the Burst connector controls the duty cycle of the laser by disabling the High Voltage Power Supply (HVPS). When BURST is “low” (or left floating), laser operation proceeds as normal. When BURST is TTL “high,” the HVPS is halted from charging as long as the BURST signal remains “high.” (The trigger signal is logically ANDed with an (inverted) version of the BURST signal.)

Control of the HVPS using the BURST signal provides several ways to modify the pulsed laser output. These include:

- gating the pulsed laser output
- producing pulsed laser output at repetition rates up to 60 Hz
- suppression of spontaneous pulses at low repetition rates
- suppression of HVPS switching frequency noise
- laser attenuation via remote control

## Pulse Gating

Figure 5-1 shows an oscilloscope trace that demonstrates the use of the BURST signal to produce a gated output of groups of pulses. The top trace shows the SYNC OUT signal with the laser internally triggered at a repetition rate of 30 Hz. The middle trace displays the TTL-level signal applied to the Burst connector from an external signal generator. The lower trace displays detection of the pulsed laser output. The combination of laser triggering and the BURST signal results in the gating of 9 laser pulses spanning about 330 ms at a duty cycle around 50%.

Pulse gating can be used with the laser triggered either internally or externally, and the BURST signal can be synchronous or asynchronous with TRIGGER.

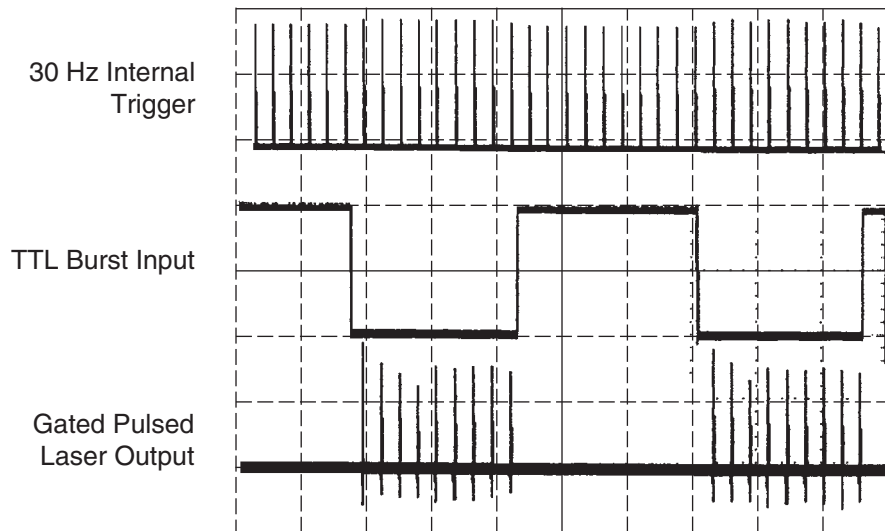

**Figure 5-1: Gating of 30-Hz Pulses Using the Burst Signal**

## Burst Output

To operate the laser between 30 and 60 Hz, place the Trigger Selection Switch in External Mode and supply a TTL external trigger at the desired rate. At the same time, supply a TTL input to the Burst connector to reduce the duty cycle of the laser. BURST should be driven “high” and kept “high” to disable the HVPS at the appropriate intervals between groups of pulses. BURST should be held “low” before the next group of pulses is to be emitted long enough (> 15 ms) to allow the HVPS to fully recharge.

It is critical to limit the Burst mode duty cycle to avoid serious damage to the laser. Both the duration of a group of Burst mode pulses and the time between groups of Burst mode pulses must be in agreement with Table 5-1.

**Table 5-1: Burst Mode Duty Cycles**

Pulse Rep Rate	Maximum duration of pulse group	Minimum interval between pulse groups
3 – 45 Hz	10 seconds	20 seconds
45 – 60 Hz	10 seconds	30 seconds

As might be expected, as the frequency of pulses is increased, the energy available in each individual pulse decreases. This pulse energy roll-off as a function of repetition rate relative to energy at 10 Hz operation is shown in Figure 5-2. Note that other pulse characteristics may change as well, such as the duration of individual pulses.

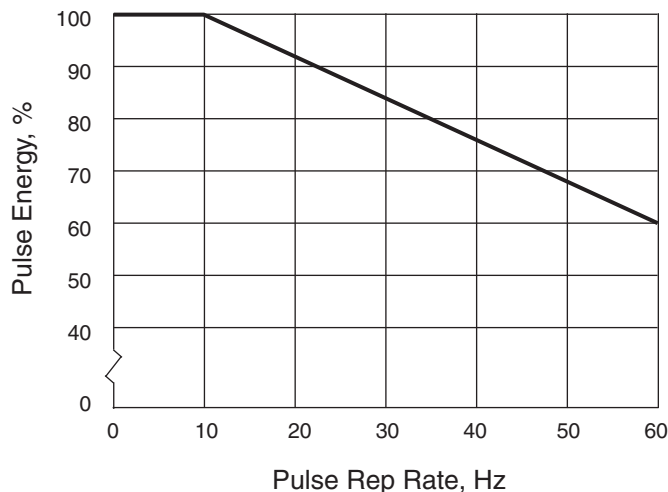

**Figure 5-2: Pulse Energy vs. Repetition Rate**

## Suppression of Spontaneous Pulses

Note



---

Suppression is not needed when internal triggering is used. When external triggering is used, the Burst signal must be driven synchronously and at the same repetition rate as the external trigger signal.

---

In non-Burst operation at low pulse repetition rates, the laser is fully charged and ready to fire for a considerable time before the arrival of a trigger pulse. Although unlikely, it is possible that some external impulse—electrical noise or even a cosmic ray particle—may trigger the laser to emit a pulse spontaneously during this time period. This can be prevented by combining the trigger signal with the Burst input.

The Burst input can be used to prevent the laser from recharging and, thus, eliminating the possibility of a spontaneous pulse. Operating in this mode requires that BURST be driven “high” immediately following the Trigger signal leading edge (which triggers the laser pulse) and held “high” until ready for laser output. BURST is then sent “low” prior to the next leading edge of the Trigger signal with sufficient time to allow the HVPS to fully recharge the laser. The HVPS requires at least 15 ms to fully charge the laser.

Note that this mode of operation is only available when external triggering is used. When internal triggering is used, an internal inhibit signal is generated that always prevents the HVPS from recharging until it is required by the next (internal) trigger signal, which is determined by the repetition rate. When Internal mode is used, the HVPS is always inhibited in the most optimum way.

Burst mode still operates with Internal triggering, however the internally generated inhibit delay sets the minimum length of time for which the HVPS is prevented from recharging.

## Noise Suppression

Note



---

The following method of operation is only applicable when using external triggering. The Burst input must be driven synchronously and at the same repetition rate as the external trigger signal.

---

In this application, the BURST signal is again used to prevent the laser from recharging immediately.

Although the laser itself generates very little EMI, some applications are sensitive to the low-level noise generated by the HVPS when it is recharging. This noise is at the HVPS switching frequency of 38 kHz and at its harmonics. In some applications, it may be advantageous to use the BURST signal to delay HVPS recharging until after the period of sensitive data collection.

Figure 5-3 shows the effects on the noise output of the HVPS by using the Burst signal. The weak switching noise output was detected by an antenna.

The top trace displays the amplified antenna pickup, while the lower trace displays the TTL Burst input. As can be seen, when BURST is “high” (i.e., inhibiting HVPS recharging), the noise level is reduced. When BURST signal is “low,” the HVPS is allowed to recharge and there is a jump in the noise level (following a 500  $\mu$ s delay inherent in the HVPS).

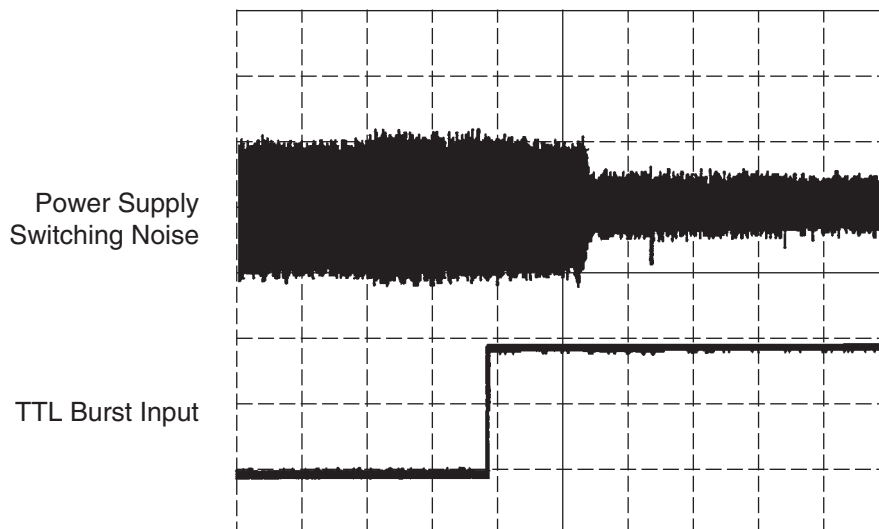

**Figure 5-3: HVPS Recharge Noise**

As before, using the Burst input for noise suppression still requires the HVPS be allowed to recharge fully for at least 15 ms before the next trigger pulse. The reduction in the spectral content of the noise is shown in the FFT displays in Figure 5-4.

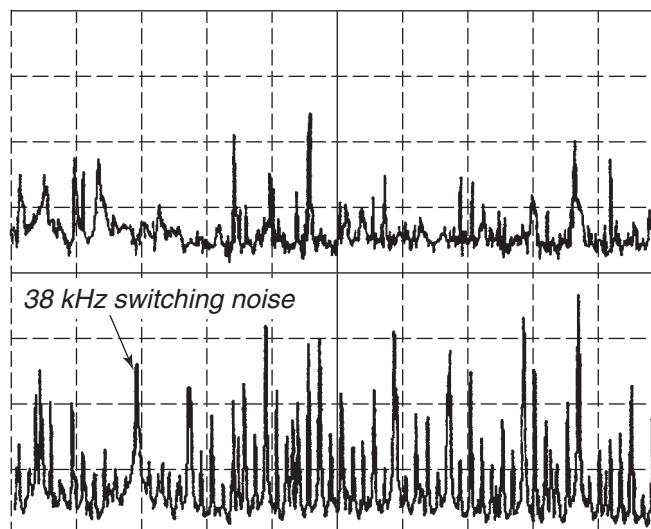

**Figure 5-4: The Noise Spectrum With (above) and Without (below) the HVPS Recharging Delay.**

### Electronic Control of Laser Energy

It is possible to attenuate the energy of the laser pulses (and the average power of the laser beam) by using the BURST signal to reduce the time allowed for the HVPS to recharge the capacitor to less than the nominal 15 ms. Because the HVPS will not have time to charge the capacitor to the 17 kV standard voltage before the laser is triggered, the nitrogen gas that is sufficiently excited to provide laser amplification is reduced. The result is lower energy output pulses.

By setting the BURST input signal to “low” 10 ms prior to triggering the laser, a reduction of laser energy of approximately 50% can be achieved (the exact duration will vary slightly from unit to unit). Extending the duration of BURST “low” to 15 ms will return the pulses to full energy, and varying this duration between 15 ms and 10 ms will vary the pulse energy between 100% and 50% in a fairly linear fashion (see Figure 5-5).

See “Burst Control” on page 2 for a description of how to vary the BURST “low” state. BURST can be employed this way using either internal or external triggering, but it should be synchronized to the trigger signal.

If the recharge time is reduced below 10 ms, laser operation will become erratic. Note that using this technique to attenuate laser energy also results in other laser specifications being altered. In particular, laser temporal jitter will become worse, as will the synchronization to the SYNC output, and energy stability will degrade.

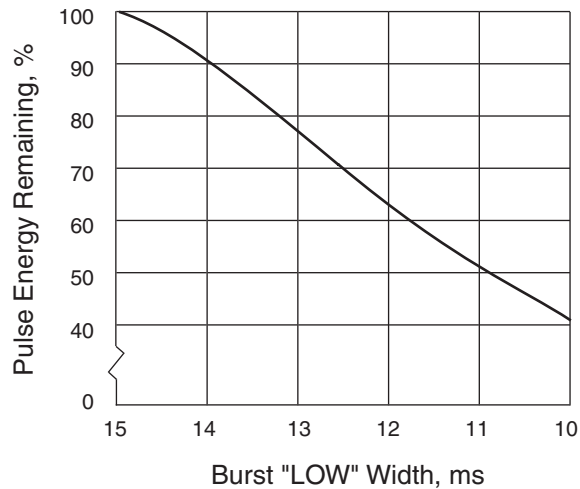
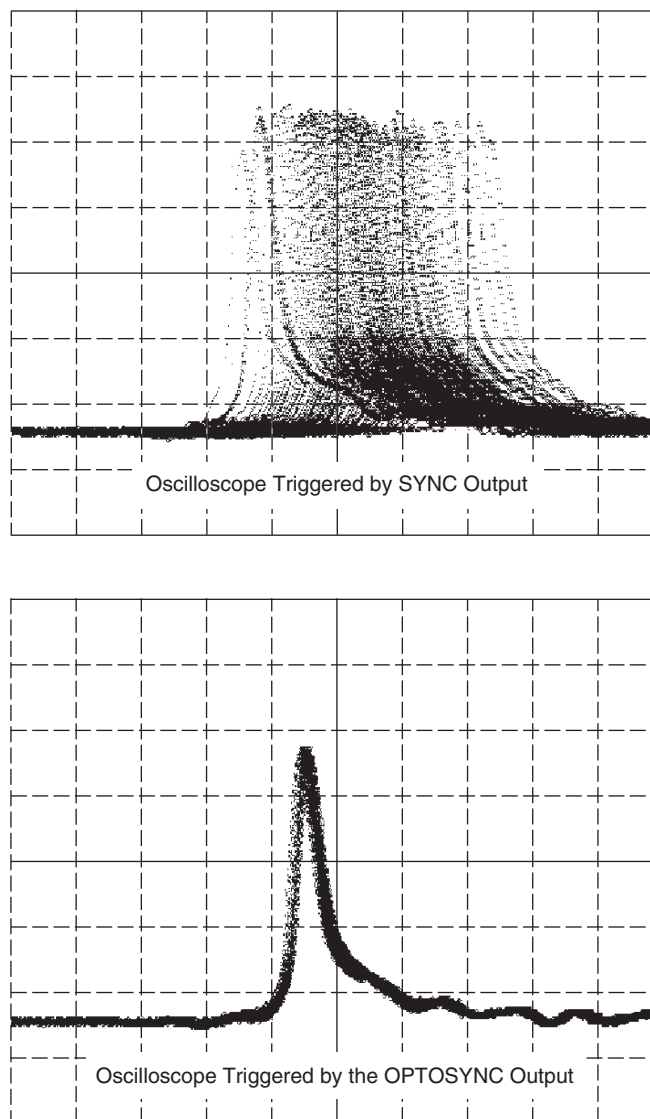

Figure 5-5: Pulse Attenuation vs. BURST Low Duration



## Using the OPTOSYNC Output

The OptoSync trigger described in Chapter 4 provides an alternative to the Sync output, where the latter is derived from the trigger pulse that starts the nitrogen discharge. The advantage of using the OPTOSYNC signal for data collection is illustrated in Figure 5-6. The top display shows an overlay of 100 pulses captured using the SYNC trigger, while the lower display compares 100 pulses using the OPTOSYNC trigger. Jitter reduction is obvious.

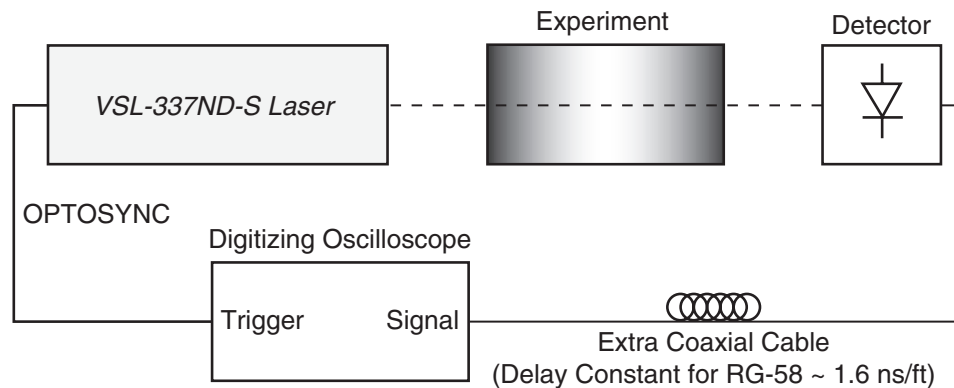

**Figure 5-6: Laser pulses captured using the SYNC input (top) versus the OPTOSYNC triggering input (bottom).**

The disadvantage of OptoSync triggering is that it *follows* the laser pulse by 50 ns (or less). For some applications, this delay is unimportant. Other applications may lend themselves to data collection techniques that compensate for this delay. Some digital data collection instruments, such as digitizing oscilloscopes, include a “pre-triggering” feature that can be use-

ful in this regard. In this case, data is stored until the arrival of the trigger pulse that initiated the event, and marks the temporal relationship of the two.

It can also prove useful to place a delay line between the detected signal and the digitizer so that the OPTOSYNC signal can “catch up” to the detected pulse. This is illustrated in Figure 5-7. Here, an extra length of coaxial cable has been inserted between the optical detector and the oscilloscope. The delay constant for RG-58 type cable is given.



**Figure 5-7: Example of Delay Compensation Using Coaxial Cable**

Experimental results are shown in Figure 5-8. The top trace shows the OptoSync output. The middle and bottom traces show the detected pulse. The middle trace has the cables for the OptoSync output and the detector equal in length, while the bottom trace includes an extra 48 feet of coaxial cable between the detector and the oscilloscope. This extra cable length produces an additional delay of approximately 70 ns, placing the detected pulse beyond the leading edge of the OptoSync signal.

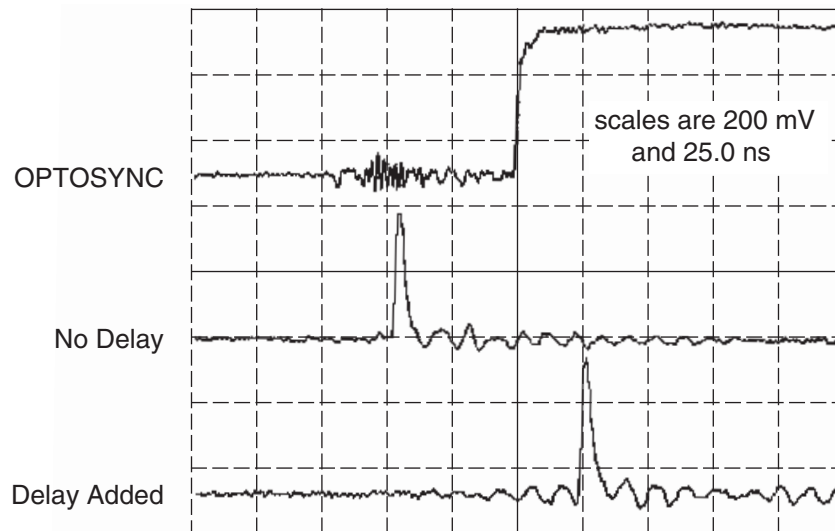

**Figure 5-8: OPTOSYNC Delay Compensation Using Coaxial Cable**

### Replacing the Plasma Cartridge

The Plasma Cartridge includes, in one integrated assembly, all the laser components that are expected to require replacement as a result of normal operation. Although replacing the Plasma Cartridge is a straightforward procedure, it is important to follow these instructions carefully. The warranty is void if damage results from improper installation.

#### Required Tools

The following tools are required to change the cartridge:

- a Phillips screwdriver
- a  $\frac{3}{32}$  in. hex ball driver
- a  $\frac{7}{64}$  in. hex ball driver
- a  $\frac{5}{16}$  in. nut driver

#### Procedure

1. Disconnect the laser ac power cord.
2. Remove all the screws from the housing, then slide the cover back towards the control panel and then lift it up. Take care not to damage the shutter.
3. Detach the connector from the OptoSync detector using the  $\frac{3}{32}$  in. hex ball driver (see Figure 6-1).

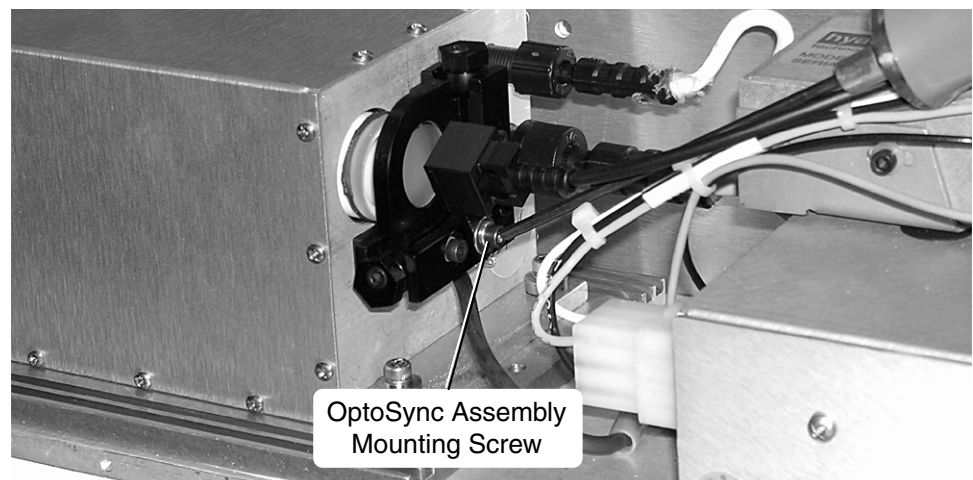

**Figure 6-1: Detach the OptoSync detector.**

4. Disconnect the Trigger Transformer cable from the Plasma Cartridge (Figure 6-2).

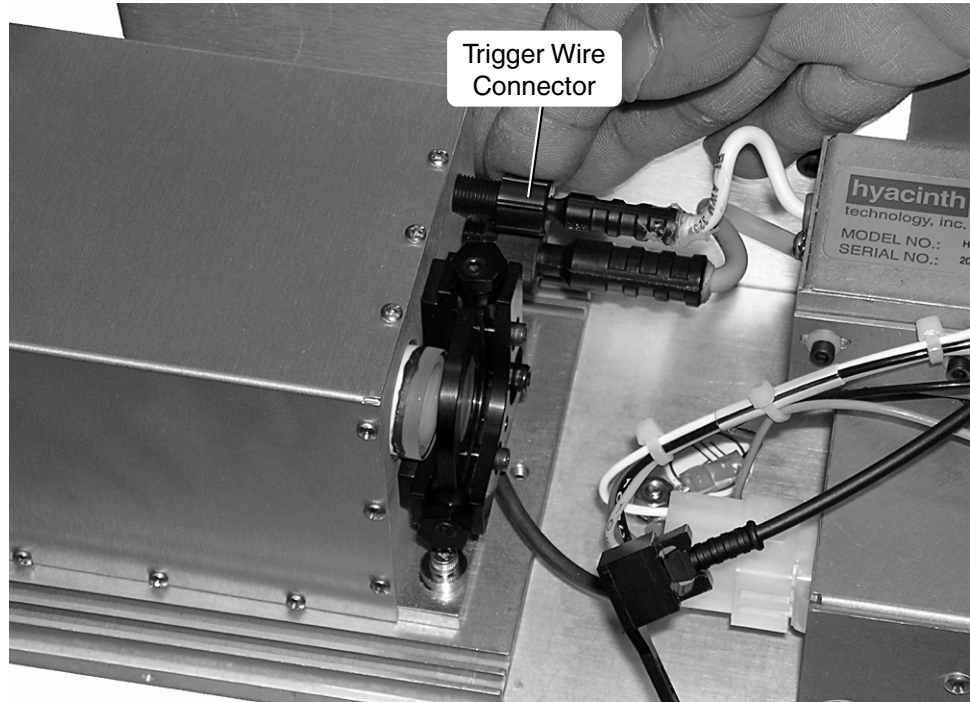

**Figure 6-2: Detach the Trigger Connector**

5. Disconnect the HVPS cable from the Plasma Cartridge (Figure 6-3).

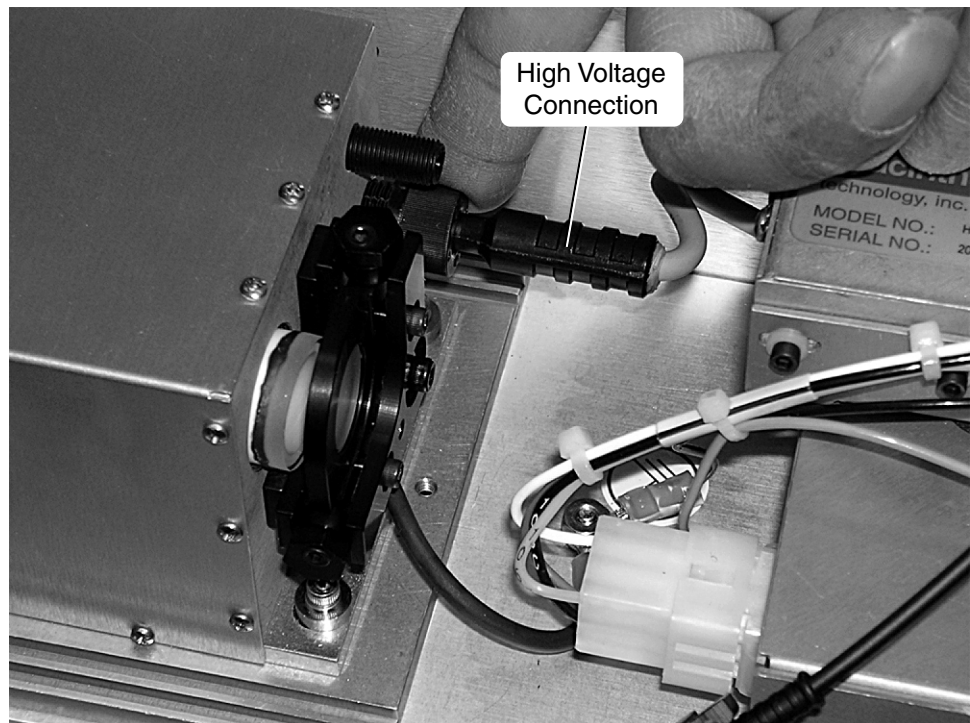

**Figure 6-3: Detach the HVPS Connector**

- Using a  $\frac{7}{64}$  in. hex ball driver, unscrew the 4 retaining screws that fasten the Plasma Cartridge to the Base Plate (Figure 6-4).

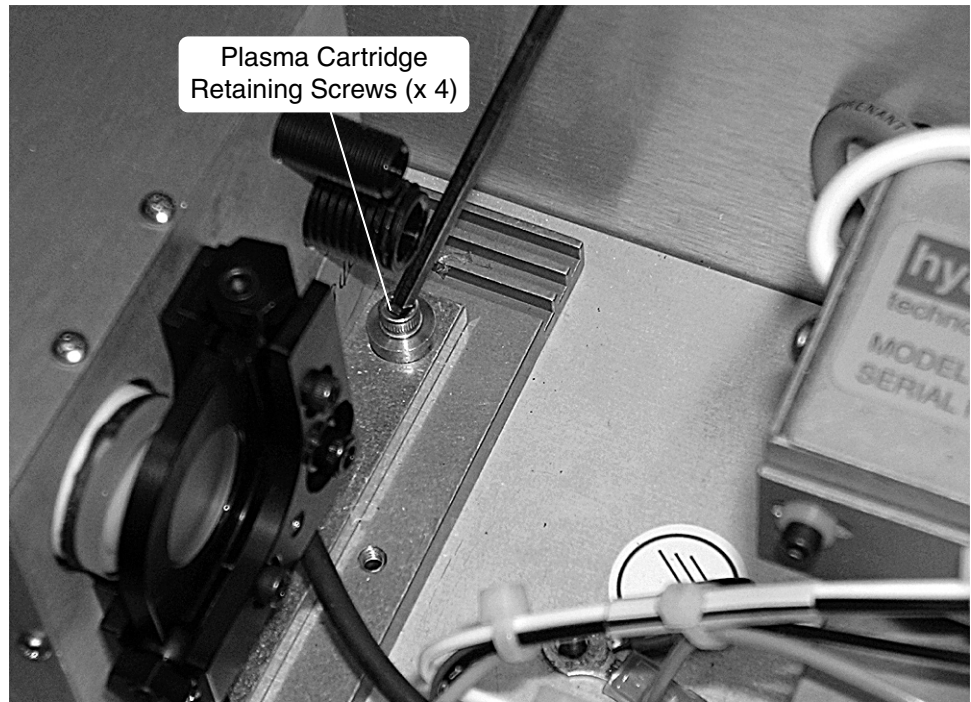

**Figure 6-4: Unfasten the Plasma Cartridge Retaining Screws (4)**

- Using a  $\frac{5}{16}$  in. nut driver, remove the ground nut and slide off the black wire that grounds the Plasma Cartridge to the Base Plate. Leave the smaller ground connections for the HVPS and Trigger Transformer in place (Figure 6-5).

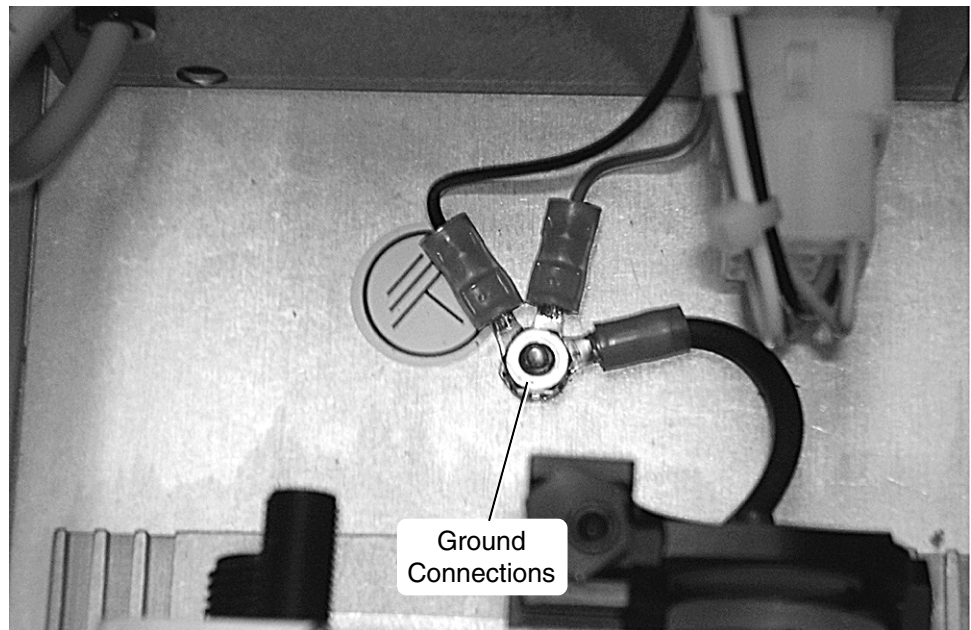

**Figure 6-5: Ground Connections**

- Carefully lift out the Plasma Cartridge (Figure 6-6).

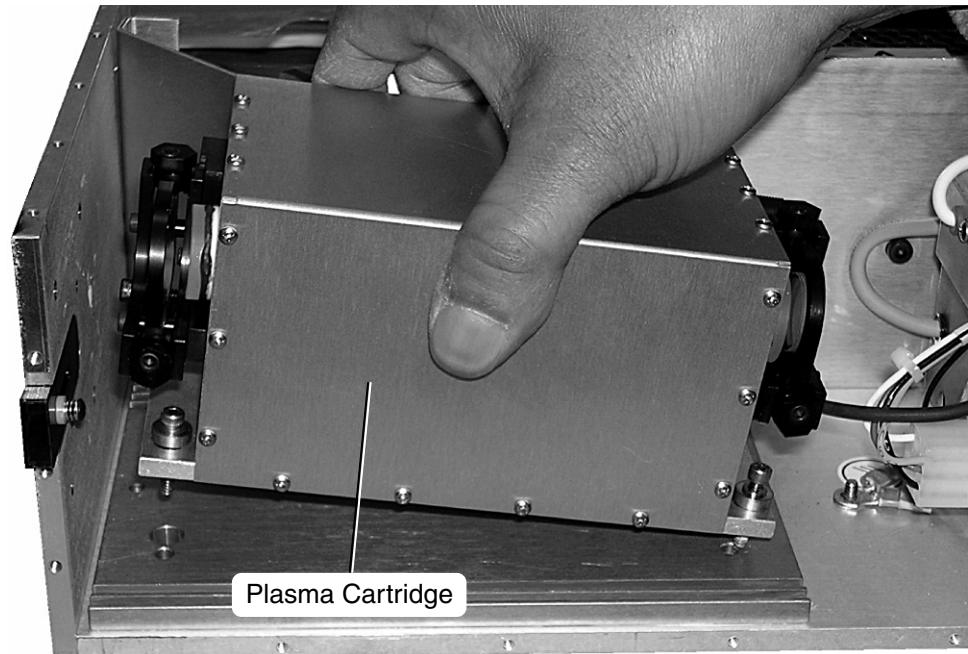

**Figure 6-6: Remove the Plasma Cartridge**

- If the Pulse Counter option is used, disconnect the lead at the back of the Plasma Cartridge (Figure 6-7).

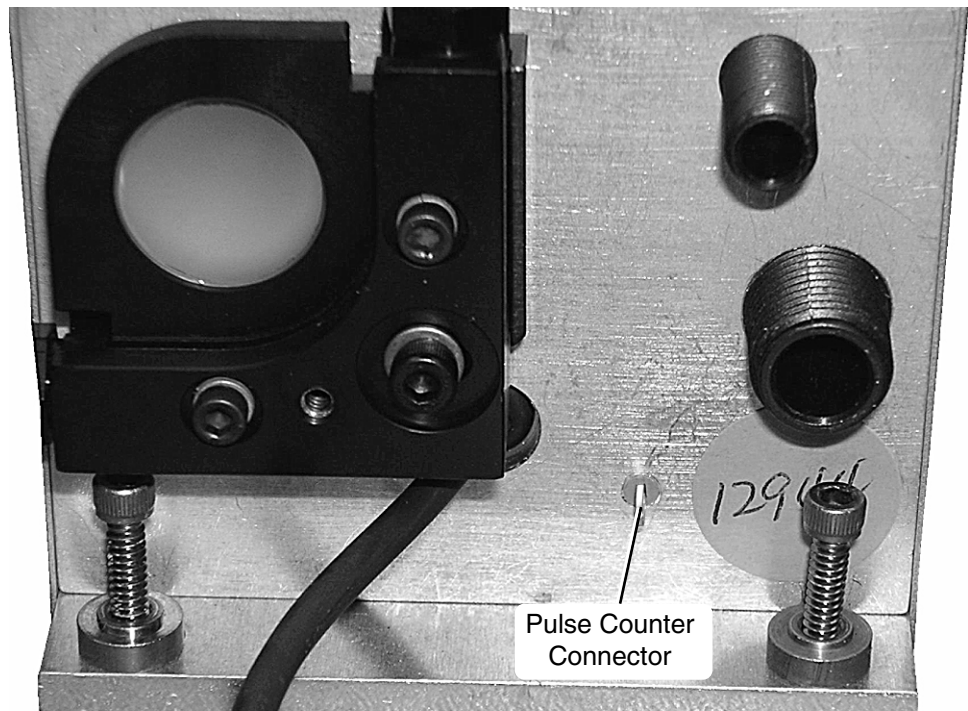

**Figure 6-7: Pulse Counter Connector**

- Place the new Plasma Cartridge onto the Base Plate.



11. If the Pulse Counter option is used, attach the counter lead to the connector on the back of the new Plasma Cartridge.
12. Reconnect the black ground wire from the Plasma Cartridge to the ground terminal (Figure 6-5).

**Warning!**



Failure to reconnect the black ground wire from the plasma cartridge to the base plate will result in a serious electrical shock hazard. Damage may also result to electrical components.

13. Attach the four retaining screws that fasten the Plasma Cartridge to the Base Plate. Be sure to orient the spacers correctly between the screws and the Base Plate (see Figure 6-8).

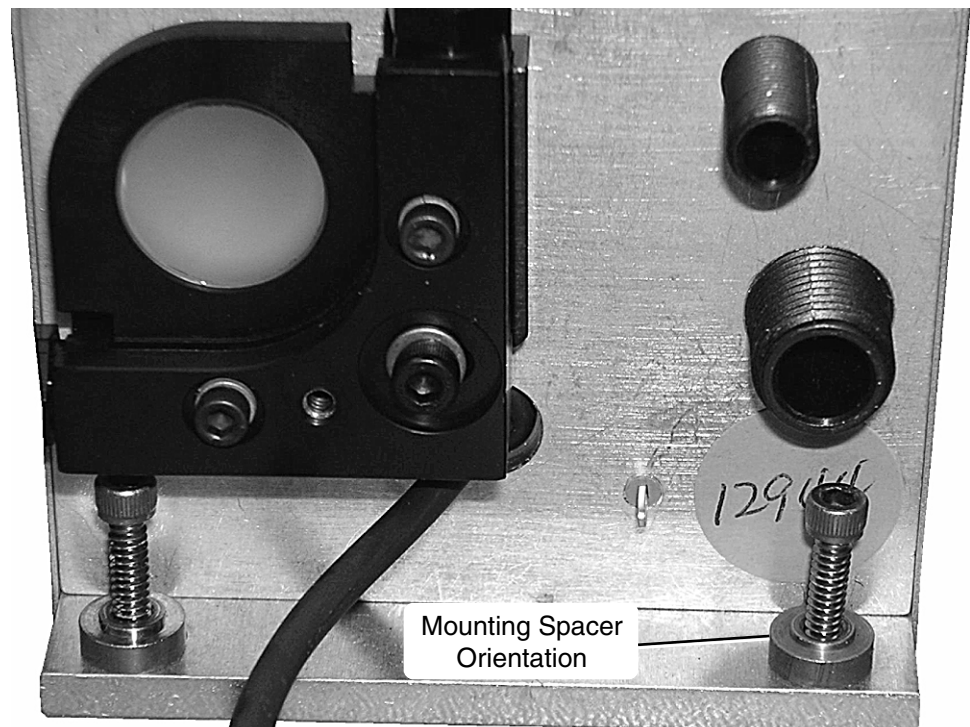

**Figure 6-8: Spacer Orientation**

14. Connect the cables from the HVPS and the Trigger Transformer to the Plasma Cartridge.
15. Separate the HVPS and trigger cables from each other to minimize the possibility that noise will trigger spontaneous laser pulses.
16. Install the cover on the laser and connect the ac power cord.
17. The laser is now ready for use. The new Plasma Cartridge should not need alignment. If, after the Plasma Cartridge has been replaced, the laser performs poorly, contact your Spectra-Physics representative.

## Troubleshooting

The *VSL-337ND-S* generally has trouble-free operation. If the laser fails to produce output, verify the following connections or settings. (Note that, while this list appears elementary, performing these checks results in the resolution of most problems typically referred to Spectra-Physics and can save a service call.)

- Verify the ac power cord is connected to the laser.
- Verify the keyswitch has been turned on.
- Verify the INTERLOCKS DEFEATED indicator is glowing green (i.e. the interlocks are closed).
- Verify the shutter is open.
- Verify the REPETITION RATE knob is *not* set to zero.

If the laser still does not produce an output beam, it is likely the Plasma Cartridge must be replaced. Other symptoms that indicate the problem lies with the Plasma Cartridge are low power and the recurrence of untriggered pulses in EXTERNAL mode.

## Accessories

The following laser accessories are available:

**Table 6-2: Accessories**

Description	Part Number
DUO Tunable Dye Laser, 360 – 700 nm	3337220-00
DUO Tunable Dye Laser, 600 – 960 nm	3337221-00
DUO Fixed Wavelength Dye Laser, 360 – 950 nm, 3 – 10 nm bandwidth	3337210-00
Fiber-Optic Coupler, SMA Connector	337702-01
200 µm diameter fused silica fiber, SMA connectors	337710-01
400 µm diameter fused silica fiber, SMA connectors	337711-01
600 µm diameter fused silica fiber, SMA connectors	337712-01
1 mm diameter fused silica fiber, SMA connectors	337714-01

## Replacement Parts

The following parts may be purchased to replace broken components:

**Table 6-1: Replacement Parts**

Description	Part Number
High Voltage Power Supply	SA1387S
Pulse Transformer	AA1307-05S
Trigger Board	BD1001-00S
Low Voltage Power Supply	4004-0790
Keyswitch	250005
Interlock Switch (internal)	250004
Fan	090003S



## Service

At Spectra-Physics, we take great pride in the reliability of our products. Considerable emphasis has been placed on controlled manufacturing methods and quality control throughout the manufacturing process. Nevertheless, even the finest precision instruments will need occasional service. Our instruments have excellent service records compared to competitive products, and we strive to provide excellent service to our customers in two ways: by providing the best equipment for the price and by servicing your instruments as quickly as possible.

Spectra-Physics maintains major service centers in the United States, Europe, and Japan. Additionally, there are field service offices in major United States cities. When calling for service inside the United States, dial our toll free number: **1 (800) 456-2552**. To phone for service in other countries, refer to the "Service Centers" listing located at the end of this section.

Order replacement parts directly from Spectra-Physics. For ordering or shipping instructions, or for assistance of any kind, contact your nearest sales office or service center. You will need your instrument model and serial numbers available when you call. Service data or shipping instructions will be promptly supplied.

To order optional items or other system components, or for general sales assistance, dial **1 (800) SPL-LASER** in the United States, or **1 (650) 961-2550** from anywhere else.

## Warranty

All parts and assemblies manufactured by Spectra-Physics are unconditionally warranted to be free of defects in workmanship and materials for the period of time listed in the sales contract following delivery of the equipment to the F.O.B. point.

Liability under this warranty is limited to repairing, replacing, or giving credit for the purchase price of any equipment that proves defective during the warranty period, provided prior authorization for such return has been given by an authorized representative of Spectra-Physics. Spectra-Physics will provide at its expense all parts and labor and one-way return shipping of the defective part or instrument (if required). In-warranty repaired or replaced equipment is warranted only for the remaining portion of the original warranty period applicable to the repaired or replaced equipment.

This warranty does not apply to any instrument or component not manufactured by Spectra-Physics. When products manufactured by others are included in Spectra-Physics equipment, the original manufacturer's warranty is extended to Spectra-Physics customers. When products manufactured by others are used in conjunction with Spectra-Physics equipment, this warranty is extended only to the equipment manufactured by Spectra-Physics.

This warranty also does not apply to equipment or components that, upon inspection by Spectra-Physics, is found to be defective or unworkable due to abuse, mishandling, misuse, alteration, negligence, improper installation, unauthorized modification, damage in transit, or other causes beyond the control of Spectra-Physics.

This warranty is in lieu of all other warranties, expressed or implied, and does not cover incidental or consequential loss.

This warranty is valid for units purchased and used in the United States only. Products shipped outside the United States are subject to a warranty surcharge.

***Returning the Instrument for Repair***

Contact your nearest Spectra-Physics field sales office, service center, or local distributor for shipping instructions or an on-site service appointment. You are responsible for one-way shipment of the defective part or instrument to Spectra-Physics.

Use the original packing boxes to secure instruments during shipment. If shipping boxes have been lost or destroyed, order new ones. Instruments can be returned only in Spectra-Physics containers.

## Service Centers

### Benelux

Telephone: (31) 40 265 99 59

### France

Telephone: (33) 1-69 18 63 10

### Germany and Export Countries\*

Spectra-Physics GmbH  
 Guerickeweg 7  
 D-64291 Darmstadt  
 Telephone: (49) 06151 708-0  
 Fax: (49) 06151 79102

### Japan (East)

Spectra-Physics KK  
 East Regional Office  
 Daiwa-Nakameguro Building  
 4-6-1 Nakameguro  
 Meguro-ku, Tokyo 153  
 Telephone: (81) 3-3794-5511  
 Fax: (81) 3-3794-5510

### Japan (West)

Spectra-Physics KK  
 West Regional Office  
 Nishi-honmachi Solar Building  
 3-1-43 Nishi-honmachi  
 Nishi-ku, Osaka 550-0005  
 Telephone: (81) 6-4390-6770  
 Fax: (81) 6-4390-2760  
 e-mail: niwamuro@splasers.co.jp

### United Kingdom

Telephone: (44) 1442-258100

### United States and Export Countries\*\*

Spectra-Physics  
 1330 Terra Bella Avenue  
 Mountain View, CA 94043  
 Telephone: (800) 456-2552 (Service) or  
 (800) SPL-LASER (Sales) or  
 (800) 775-5273 (Sales) or  
 (650) 961-2550 (Operator)  
 Fax: (650) 964-3584  
 e-mail: service@splasers.com  
 sales@splasers.com  
 Internet: www.spectra-physics.com

\* And all European and Middle Eastern countries not included on this list.

\*\* And all non-European or Middle Eastern countries not included on this list.



# Notes

---

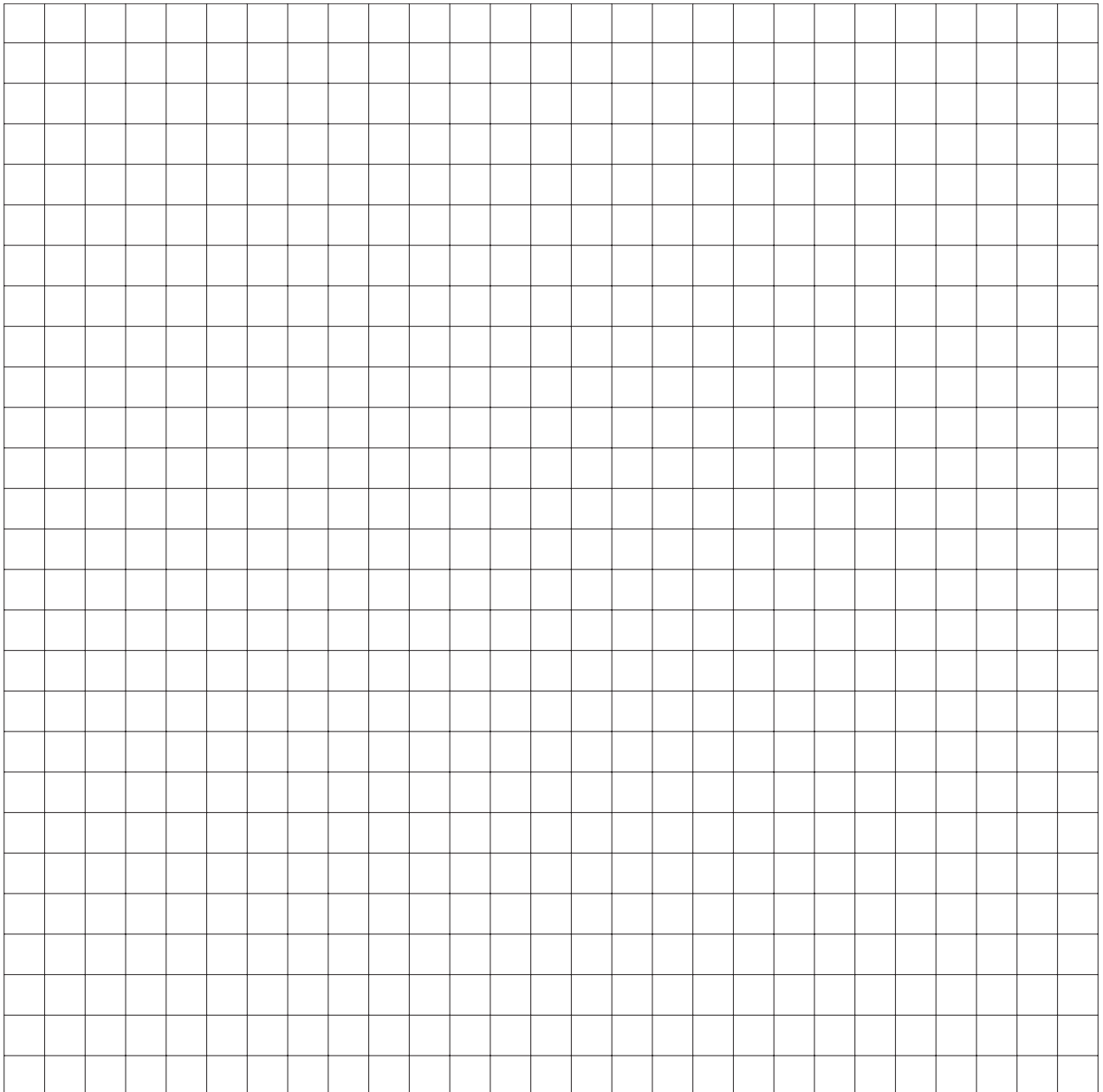



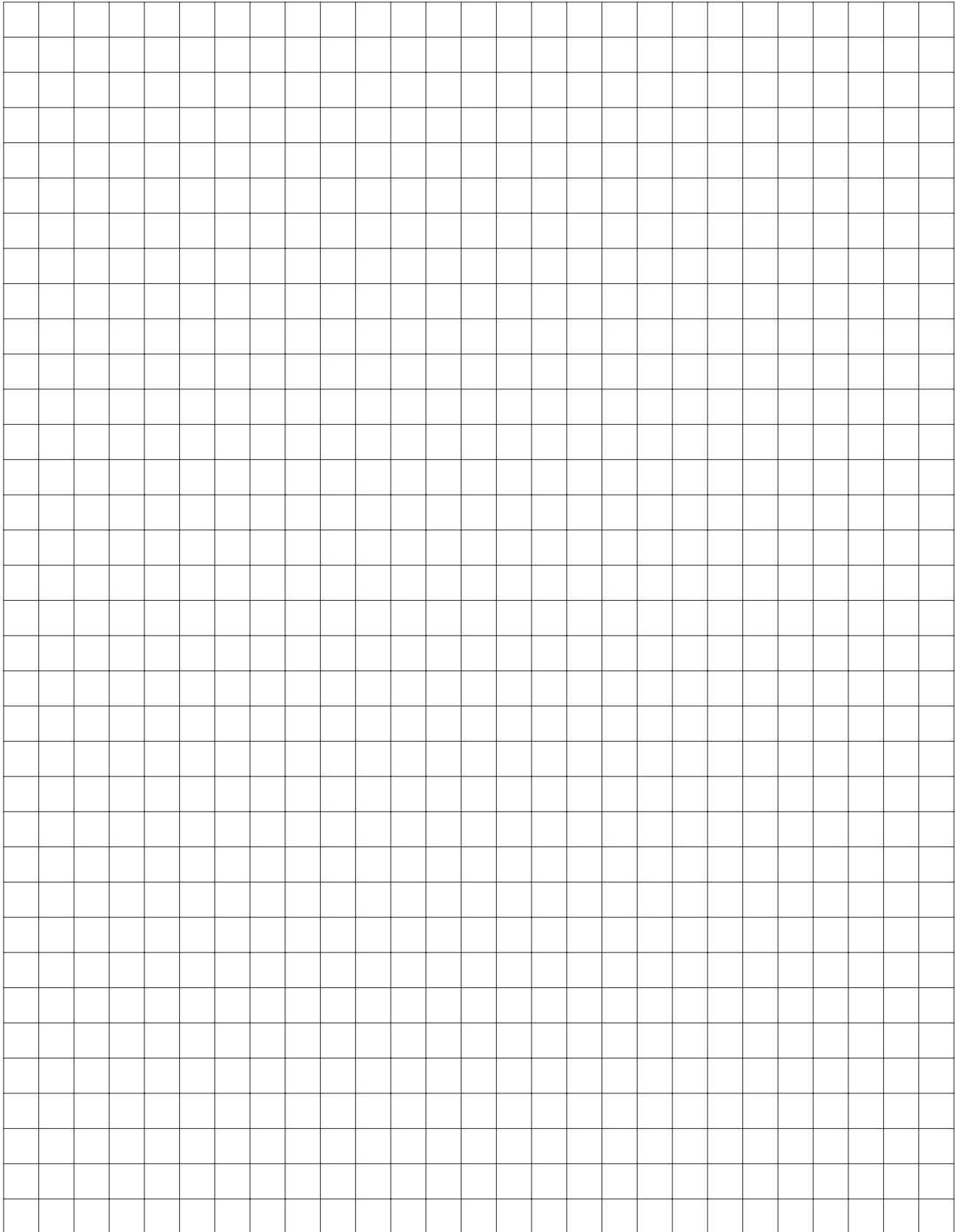





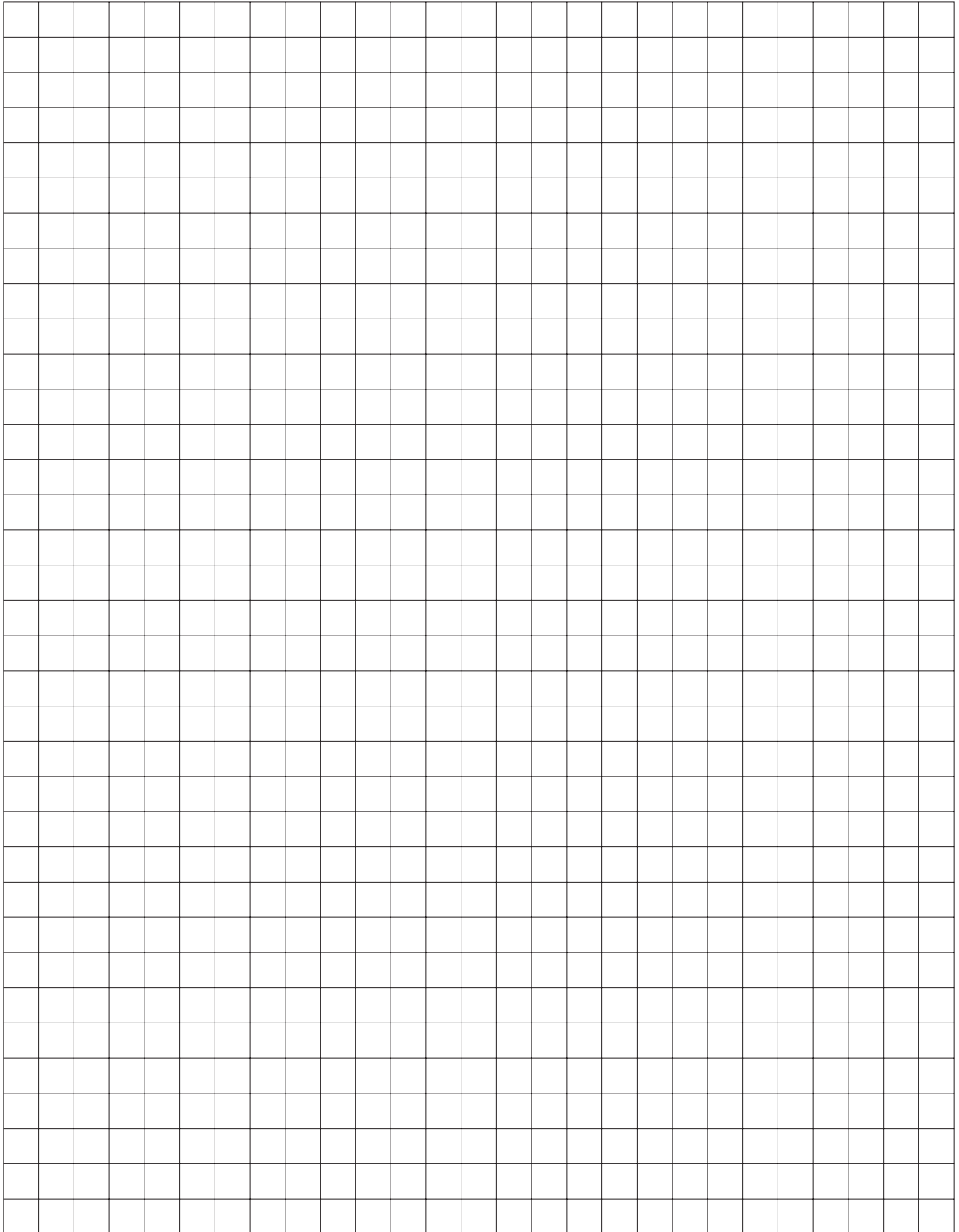



# Report Form for Problems and Solutions

---

We have provided this form to encourage you to tell us about any difficulties you have experienced in using your Spectra-Physics instrument or its manual—problems that did not require a formal call or letter to our service department, but that you feel should be remedied. We are always interested in improving our products and manuals, and we appreciate all suggestions.

Thank you.

**From:**

Name \_\_\_\_\_

Company or Institution \_\_\_\_\_

Department \_\_\_\_\_

Address \_\_\_\_\_

Instrument Model Number \_\_\_\_\_ Serial Number \_\_\_\_\_

**Problem:** \_\_\_\_\_

\_\_\_\_\_

\_\_\_\_\_

\_\_\_\_\_

**Suggested Solution(s):** \_\_\_\_\_

\_\_\_\_\_

**Mail To:**

Spectra-Physics, Inc.  
SSL Quality Manager  
1335 Terra Bella Avenue, M/S 15-50  
Post Office Box 7013  
Mountain View, CA 94039-7013  
U.S.A.

E-mail: [sales@splasers.com](mailto:sales@splasers.com)  
[www.spectra-physics.com](http://www.spectra-physics.com)

**FAX to:**

Attention: Quality Manager  
(650) 961-7101

